

# Visual Assessment for the Proposed Pure Source Mine

*Project Number:*

**PSM002**

*Prepared for:*

**Monte Cristo Commercial Park (Pty) Ltd**

Units 18 & 19 Villaggio D' Amico, Tuscan Estate, Van Heerden Street, Libradene, Boksburg

Email: sand@puresource.co.za

Tel: 011 913 1719

Fax: 086 230 5262

*Compiled by:*



**Hydrospatial (Pty) Ltd**

17 Sonop Place, Randpark, 2194

Email: andypirie82@gmail.com

Tel: 084 441 9539

**July 2019**

## DOCUMENT CONTROL

<b>Project Name</b>	Pure Source Mine Mining Right Application
<b>Report Type</b>	Visual Assessment
<b>Client</b>	Monte Cristo Commercial Park (Pty) Ltd
<b>Project Number</b>	PSM002
<b>Report Number</b>	02
<b>Report Status</b>	Final
<b>Submission Date</b>	31 July 2019
<b>Author</b>	Andy Pirie
<b>Author Signature</b>	

## TABLE OF CONTENTS

<b>EXECUTIVE SUMMARY .....</b>	<b>VIII</b>
<b>1 INTRODUCTION AND BACKGROUND .....</b>	<b>1</b>
1.1 Project Location and Study Area.....	1
1.2 Project Description.....	1
1.2.1 Mine Infrastructure and Alternatives.....	1
1.2.2 Mining Method and Resource .....	6
1.2.2.1 Sand Mining.....	6
1.2.2.2 Aggregate Mining.....	7
1.2.2.3 Alluvial Diamond Mining.....	7
1.2.3 Mining Schedule and Project Phases.....	7
1.2.4 Employment and Operating Hours .....	9
1.2.5 Offices, Workshop and Change House .....	9
1.2.6 Sewage.....	9
1.2.7 Waste and Storage of Dangerous Goods.....	9
1.2.8 Roads .....	9
1.2.9 Post Mining Land Use.....	10
1.3 Legislative Requirements and Guidelines .....	10
1.3.1 International.....	10
1.3.2 National .....	11
<b>2 SCOPE OF WORK .....</b>	<b>11</b>
<b>3 METHODOLOGY .....</b>	<b>12</b>
3.1 Site Investigation .....	12
3.2 Baseline Visual and Aesthetic Environment .....	12
3.3 Visual and Aesthetic Evaluation .....	13
3.3.1 Visibility and Visual Exposure .....	13
3.3.2 Visual/Scenic Quality .....	13
3.3.3 Visual Absorption Capacity .....	13
3.3.4 Visual Intrusion .....	14
3.3.5 Viewer Sensitivity.....	15
3.4 Impact Assessment.....	15
3.4.1 Part A: Defining Consequence in Terms of Magnitude, Duration and Spatial Scale	15
3.4.2 Part B: Determining the Consequence Rating.....	16
3.4.3 Part C: Determining Significance Rating .....	17
<b>4 ASSUMPTION AND LIMITATIONS.....</b>	<b>17</b>
<b>5 BASELINE VISUAL AND AESTHETIC ENVIRONMENT .....</b>	<b>18</b>

5.1	Topography.....	18
5.2	Land Cover and Use.....	18
5.3	Landscape Characterisation .....	19
5.4	Visual Receptors.....	19
5.5	Sense of Place.....	19
5.6	Protected Areas and Cultural and Heritage Landscapes.....	22
<b>6</b>	<b>VISUAL AND AESTHETIC EVALUATION .....</b>	<b>22</b>
6.1	Visibility and Visual Exposure .....	22
6.2	Visual/Scenic Quality .....	27
6.3	Visual Absorption Capacity .....	27
6.4	Visual Intrusion .....	27
6.5	Viewer Sensitivity.....	28
<b>7</b>	<b>IMPACT ASSESSMENT.....</b>	<b>29</b>
7.1	Project Phase Description.....	29
7.1.1	Construction Phase.....	29
7.1.2	Operational and Rehabilitation Phase.....	29
7.1.3	Post Mine Closure .....	29
7.2	Cumulative Impacts .....	29
7.3	Impact Assessment and Mitigation Measures .....	30
<b>8</b>	<b>CONCLUSION AND RECOMMENDATIONS .....</b>	<b>35</b>
<b>9</b>	<b>REFERENCES .....</b>	<b>35</b>
	<b>APPENDIX A: PURE SOURCE MINE INFORMATION PROVIDED BY SKETS.....</b>	<b>36</b>

## LIST OF TABLES

Table 1-1: Infrastructure heights .....	6
Table 3-1: Visual absorption capacity criteria .....	14
Table 3-2: Visual intrusion criteria .....	14
Table 3-3: Viewer sensitivity criteria .....	15
Table 3-4: Consequence rating definitions .....	16
Table 3-5: Consequence rating methodology.....	17
Table 3-6: Significance rating methodology.....	17



Table 5-1: Cultural and heritage sites within the Project area.....	22
Table 6-1: Summary of the visible areas and affected visual receptors for the three infrastructure alternatives.....	23
Table 6-2: Summary of the viewer sensitivity of the Project.....	28
Table 7-1: Impact assessment.....	31

## LIST OF FIGURES

Figure 1-1: Project location .....	2
Figure 1-2: Alternative 1: mine infrastructure layout plan.....	3
Figure 1-3: Alternative 2: mine infrastructure layout plan.....	4
Figure 1-4: Alternative 3: mine infrastructure layout plan.....	5
Figure 1-5: Yearly open pit mining schedule .....	8
Figure 3-1: Dusty conditions over the Project area (photograph taken from the southern boundary of the project area looking north).....	12
Figure 5-1: The role of topography in the visibility of a project.....	18
Figure 5-2: Topography of the study area .....	20
Figure 5-3: Land cover and use within the study area .....	21
Figure 6-1: Schematic from Vaal Oewer looking over the Project area in a south-easterly direction .....	23
Figure 6-2: Project visibility for the alternative 1 mine infrastructure layout plan.....	24
Figure 6-3: Project visibility for the alternative 2 mine infrastructure layout plan.....	25
Figure 6-4: Project visibility for the alternative 3 mine infrastructure layout plan.....	26

---

## GLOSSARY OF TERMS

### **Zone of Potential Influence**

The area defined as the radius about an object beyond which the visual impact of its most visible features will be insignificant.

### **Landscape Character**

The individual elements that make up the landscape, including prominent or eye-catching features such as hills, valleys, woods, trees, water bodies, buildings and roads.

### **Sense of Place**

Sense of place is the unique value that is allocated to a specific place or area through the cognitive experience of the user or viewer. According to Lynch (1992), sense of place “is the extent to which a person can recognise or recall a place as being distinct from other places – as having a vivid, unique, or at least particular, character of its own”.

### **Aesthetic Value**

Aesthetic value is the emotional response derived from the experience of the environment with its particular natural and cultural attributes. The response can be either to visual or non-visual elements and can embrace sound, smell and any other factor having a strong impact on human thoughts, feelings and attitudes. The aesthetic value encompasses more than the seen view, visual quality or scenery, and includes atmosphere, landscape character and sense of place.

### **Visibility**

The area/points from which project components will be visible. The visibility is determined through a viewshed analysis.

### **Viewshed**

The two dimensional spatial pattern created by an analysis that defines areas, which contain all possible observation sites from which an object would be visible.

### **Visual Intrusion**

The nature of intrusion of an object on the visual quality of the environment resulting in its compatibility (absorbed into the landscape elements) or discord (contrasts with the landscape elements) with the landscape and surrounding land uses.

### **Visual Exposure**

The visual exposure is the relative visibility of a development or feature in a landscape (Oberholzer, 2005). The visual exposure decreases as the distance between the development/feature and visual receptor increases.

## **Visual Absorption Capacity**

The Visual Absorption Capacity (VAC) is the potential of the landscape to conceal the proposed development as a result of topography, vegetation or synthetic features (Oberholzer, 2005).

### **Visual receptor**

A viewer or viewpoint from where the proposed development is visible.

## DECLARATION OF INDEPENDENCE

I, Andy Pirie declare that:

- I act as an independent specialist in this application;
- I will perform the work relating to the application in an objective manner, even if this results in views and findings that are not favourable to the applicant;
- I declare that there are no circumstances that may compromise my objectivity in performing such work;
- I have the expertise in conducting the specialist study relevant to this application, including knowledge of the various Acts, regulations and any guidelines that have relevance to the proposed project;
- I will comply with the Acts, regulations and all other applicable legislation;
- I have no, and will not engage in no conflicting interests in the undertaking of this study;
- I undertake to disclose to the applicant and the competent authority all material information in my possession that reasonably has or may have the potential of influencing any decision to be taken with respect to the application by the competent authority; and the objectivity of any report, plan or document to be prepared by myself for submission to the competent authority; and
- All the particulars furnished by me in this report are true and correct.



---

Andy Pirie

---

## EXECUTIVE SUMMARY

### Introduction and Background

Hydrospatial (Pty) Ltd (hereafter Hydrospatial) was appointed by Monte Cristo Commercial Park (Pty) Ltd (hereafter the client) to conduct a Visual Impact Assessment (VIA) study for an environmental authorisation and a Mining Right Application (MRA) process, for the Pure Source Mine (hereafter the Project). The Project is located near Vaal Oewer on the southern side of the Vaal River within Free State Province of South Africa. The study area which forms the zone of potential influence for the visual assessment, includes a 5 kilometre (km) radius around the Project area.

The Project will involve the development of an open pit mine, processing plant and associated infrastructure. Sand, aggregate and alluvial diamonds are proposed to be mined in a phased open pit mining process, using a “truck and shovel” method. The anticipated Life of Mine (LoM) is 30 years. The following mine infrastructure is proposed:

- Dams;
- Wash plant for the washing of mined sand;
- Rotary pan processing plant for alluvial diamond mining;
- Potential alluvial diamond X-ray and/or flow sorting facility;
- Clean and dirty water management infrastructure such as Pollution Control Dams (PCD), water recycling plan (part of the wash plant), settling ponds, stormwater runoff structures, water pipeline network and pump stations;
- Drying and screening plants; and
- Topsoil and Run of Mine (ROM) stockpiles.

Additional mining and processing infrastructure will include haul roads, workshop, weighbridge and offices, conveyor systems, powerlines, change houses, staff accommodation and recreation facilities and portable chemical ablution facilities for employees during the construction and operational phases. Three alternative mine infrastructure layout plans are being considered, with the most appropriate from an environmental, economic and buffer zone perspective selected.

### Scope of Work

The scope of work for the VIA included the following:

- Provide a baseline (pre-construction and mining) description of the visual and aesthetic characteristics of the area;
- Provide a visual and aesthetic evaluation of the Project; and
- Conduct an impact assessment to assess the visual impacts of the Project.

---

## Baseline Visual and Aesthetic Environment

The topography of the study area can be described as undulating. The land cover of the study area consists mostly of grassland and cultivated land. Thicker riverine vegetation occurs along the banks of the Vaal River. The Project area is currently used for crop and game farming. Directly to the north of the Project, a housing development is located at Vaal Oewer on an elevated ridge. A number of further housing developments are located along the Vaal River towards the north-west and west of the Project near Lindequesdrif. Guesthouses, lodges and resorts are fairly common in the area, as the Vaal River is a popular weekend and holiday destination, offering recreational activities such as boat cruisers, water sports and angling. Sand mining activities are evident directly south, south-east and west of the Project. Active sand mines occur on the adjacent properties to the Project and include Sweet Sensations Vaal Sand mine to the west, and Tja Naledi Beafase Investment Holdings to the south.

The study area can be broadly divided into three main categories:

- Agricultural areas – crop and livestock agriculture are the dominant land use in the area;
- Residential/housing and accommodation – housing developments and places offering accommodation, occur mostly along the Vaal River; and
- Sand mining activities.

The following visual receptors have been identified within a 5 km radius of the Project area:

- Residential/housing developments, particularly those located along the Vaal River to the north and west of the Project;
- Places providing accommodation (guesthouses, resorts, lodges and campsites);
- Conference centres;
- Farmhouses; and
- Motorists on roads within the surrounding area.

In terms of sense of place, crop and livestock farming areas, which dominate the landscape, largely evoke a feeling of a farming community, while along the Vaal River, where residential houses and places of accommodation are located, a tranquil sense of place is evoked. The sand mining areas evoke an open and barren sense of place, which is typically associated with open pit mining activities.

## Visual and Aesthetic Evaluation

Viewshed analysis modelling was undertaken to determine the visibility of the three mine infrastructure alternatives on the surrounding landscape. For all three alternatives, the Project will have a high visual exposure on visual receptors located at Vaal Oewer and Lindequesdrif, as well for other receptors located within a 2 km buffer. This includes a campsite, conference centre, resorts, lodges, and a number of houses.

The visual quality of the area was determined to be high along the Vaal River, and medium further back from the river, where grassland and cultivated land dominate the landscape. The inactive and active sand mining areas have a low visual quality.

The Visual Absorption Capacity (VAC) of the landscape in which the Project area is located, has a moderate potential to conceal the Project. This is due to the mine infrastructure and pits being mostly located in grassland and moderately undulating topography.

The proposed Project will partially fit in with the existing active sand mines in the area. However, open pit mining is likely to take place on a bigger scale than what is currently being undertaken, and will result in a clearly noticeable mining area. For these reasons, the Project will exert a moderate visual intrusion on the existing landscape.

The viewer sensitivity was determined to be high for the houses, resorts, lodges, conference centres and campsites that will have a line of site of the proposed mine.

### **Impact Assessment**

Although the Project is located in a historical and active sand mining area, the scale of the Project in comparison to other sand mining in the area, moderate VAC of the landscape to conceal the Project, high visual quality along the Vaal River, and high viewer sensitivity of houses and places of accommodation within a 2 km buffer of the Project, will result in an overall high visual impact. The main sources of visual impact will be the transformation of grassland and agricultural land to open barren areas through open pit mining, generation of dust from exposed areas, increased heavy machinery and vehicular movement, and the erection of mine infrastructure. This, however, can be mitigated to an overall medium visual impact, by ensuring that dust suppression measures are strictly and timeously adhered to, concurrent rehabilitation takes place through re-shaping and re-vegetation, down lighting and shielding is used, and ensuring that mine infrastructure blends into the surrounding landscape through careful positioning and painting of infrastructure.

From a visual perspective, infrastructure alternative 1 has the largest visible area within the study area, affecting the most visual receptors. This is followed by alternative 2, and then alternative 3. The reason for alternative 1 having the largest visible area, is because it is located on higher ground than the other alternatives. However, as indicated in Table 6-1, alternative 2 and 3 do not significantly affect a much larger visible area, or a significantly greater number of visual receptors than alternative 1.

# 1 INTRODUCTION AND BACKGROUND

Hydrospatial (Pty) Ltd (hereafter Hydrospatial) was appointed by Monte Cristo Commercial Park (Pty) Ltd (hereafter the client) to conduct a Visual Impact Assessment (VIA) study for an environmental authorisation and a Mining Right Application (MRA) process, for the Pure Source Mine (hereafter the Project).

## 1.1 Project Location and Study Area

The Project is located near Vaal Oewer on the southern side of the Vaal River within Free State Province of South Africa. The Project is located on portions 3, the remaining extent of portion 1, and the remaining extent of the farm Woodlands 407. The study area which forms the zone of potential influence for the visual assessment, includes a 5 kilometre (km) radius around the Project area. The location of the Project and study area are indicated on Figure 1-1.

## 1.2 Project Description

### 1.2.1 Mine Infrastructure and Alternatives

Three alternative mine infrastructure layout plans are being considered, with the most appropriate from an environmental, economic and buffer zone perspective selected. The three alternative mine infrastructure layout plans are indicated on Figure 1-2, Figure 1-3 and Figure 1-4. The following mine infrastructure is proposed:

- Dams;
- Wash plant for the washing of mined sand;
- Rotary pan processing plant for alluvial diamond mining;
- Potential alluvial diamond X-ray and/or flow sorting facility;
- Clean and dirty water management infrastructure such as Pollution Control Dams (PCD), water recycling plan (part of the wash plant), settling ponds, stormwater runoff structures, water pipeline network and pump stations;
- Drying and screening plants; and
- Topsoil and Run of Mine (ROM) stockpiles.

Additional mining and processing infrastructure will include haul roads, workshop, weighbridge and offices, conveyor systems, powerlines, change houses, staff accommodation and recreation facilities and portable chemical ablution facilities for employees during the construction and operational phases. Please refer to Appendix A for more information.

The mine infrastructure heights are indicated in Table 1-1. More information on the infrastructure can be obtained in Appendix A.



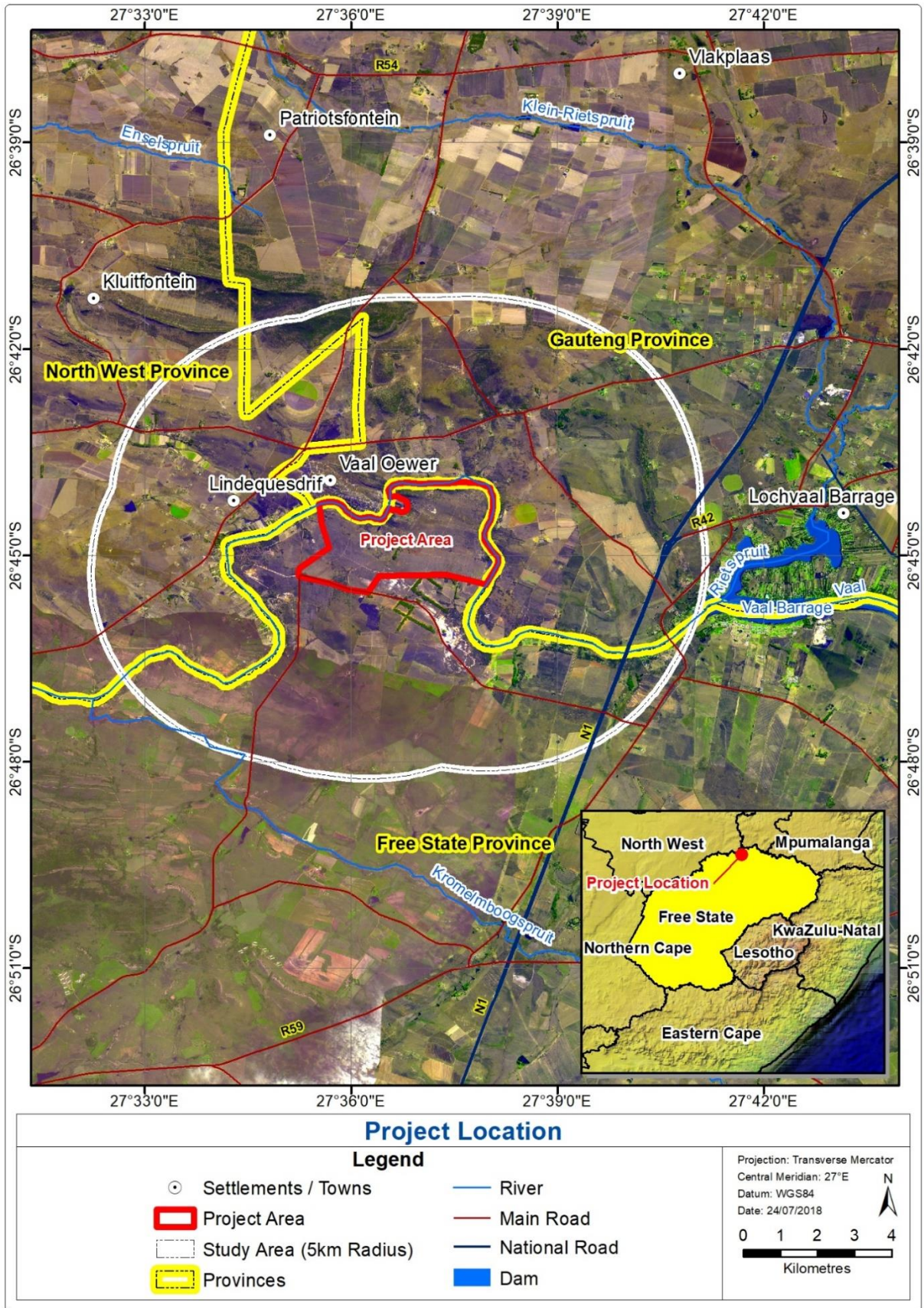

Figure 1-1: Project location



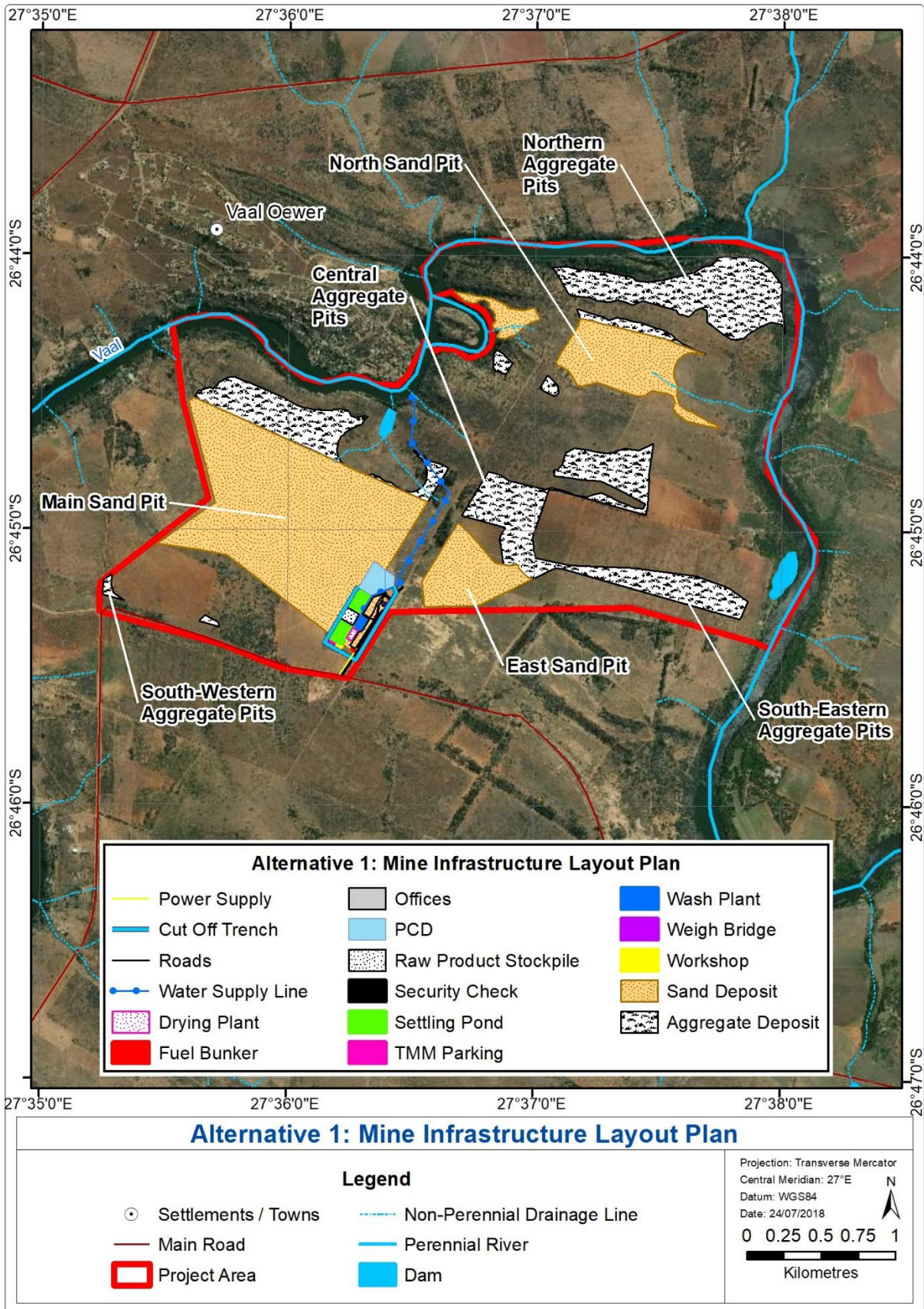

Figure 1-2: Alternative 1: mine infrastructure layout plan



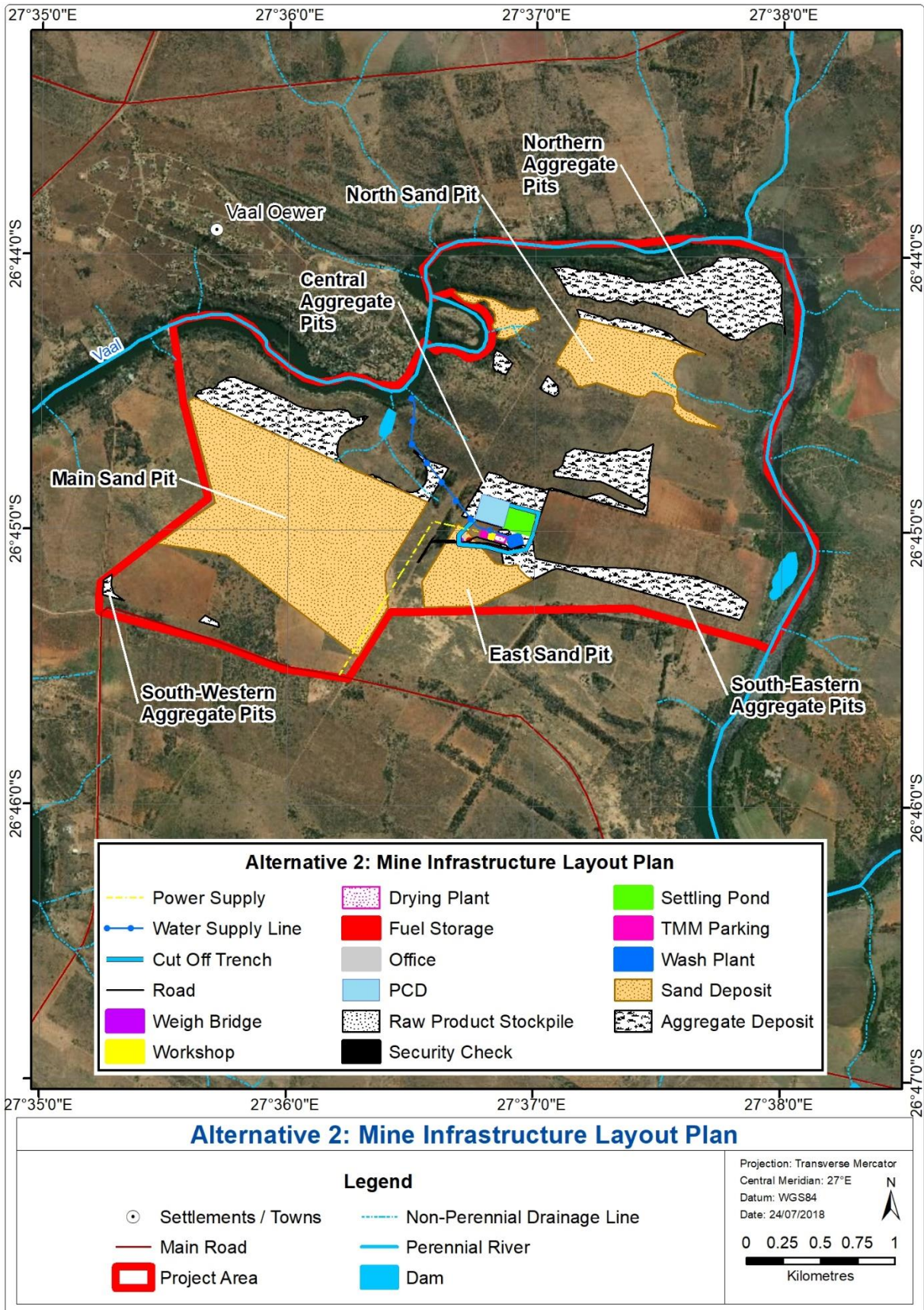

Figure 1-3: Alternative 2: mine infrastructure layout plan



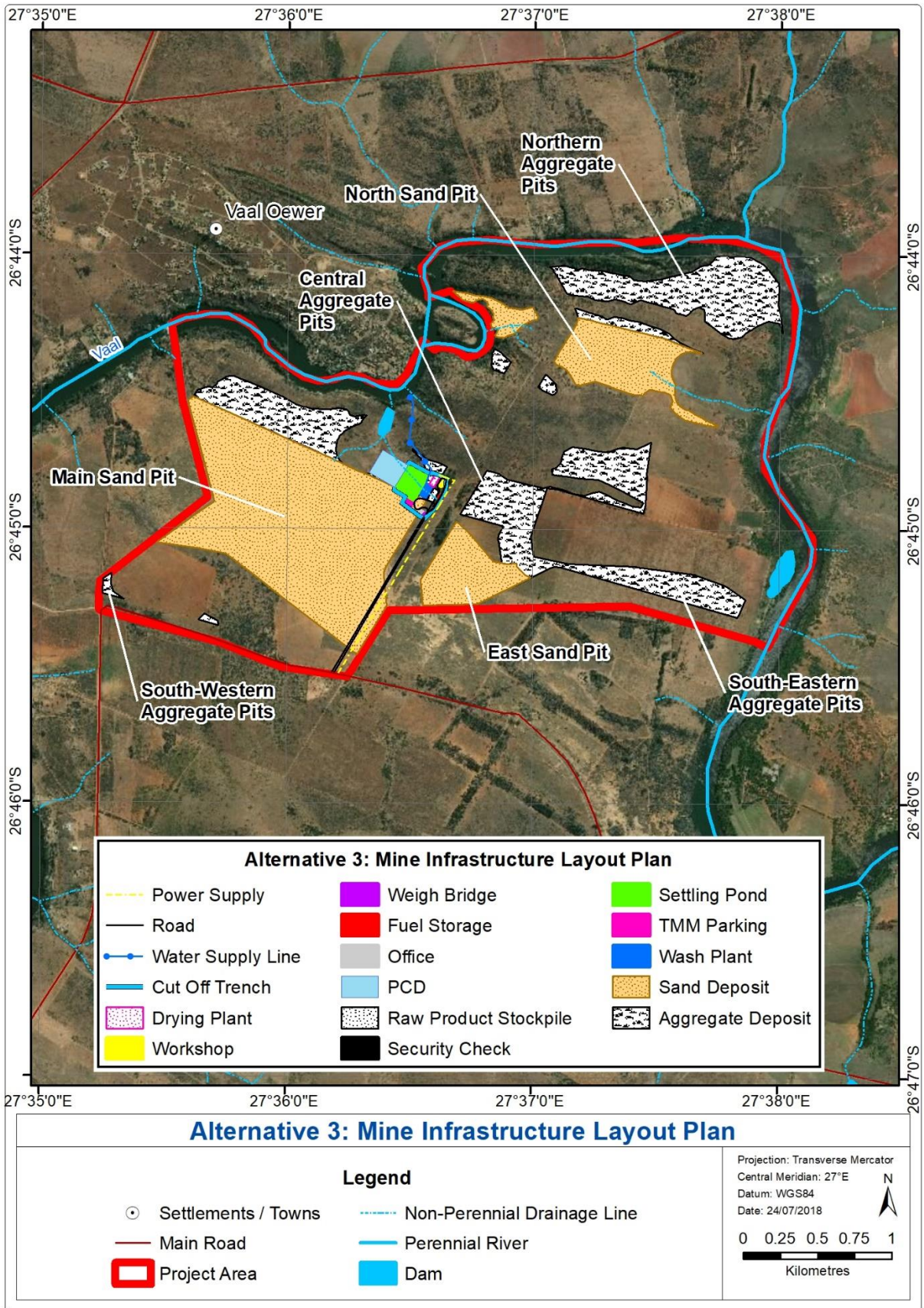

Figure 1-4: Alternative 3: mine infrastructure layout plan

**Table 1-1: Infrastructure heights**

	Length	Width	Height	Allowed Footprint
<b>Mobile Screen</b>	18,89m	18.72m	6.7m	N/A
<b>EvoWash M4500 dual sand (capacity 150T/H)</b>	6.8m	2.3m	8m	85x70m 5 950m <sup>2</sup>
<b>Aqua Cycle A1500</b>	16.7m	16.7m	±6m incl. catwalk	
<b>Rotary drying plant</b>	49m (from feeder bins to silo)	18.7m	6m (excl. silos) 250t silo = 25.5m 200t silo = 21.4m 150t silo = 17.2m	80x40m 3 200m <sup>2</sup>
<b>Fluid bed drying plant</b>	18.5m	8.5m	13.14m (excl. silos) 250t silo = 25.5m 200t silo = 21.4m 150t silo = 17.2m	80x40m 3 200m <sup>2</sup>
<b>Workshop area</b>	100m	30m	±10m	100x30m 3 000m <sup>2</sup>
<b>Fuel bunker area</b>	20	8	±4m	160m <sup>2</sup>
<b>Administrative offices And weighbridge office</b>	Not yet determined	Not yet determined	Triple storey	60x40m 2 400m <sup>2</sup>
<b>Run of Mine stockpile (±48 000m<sup>3</sup> capacity)</b>	100m	80m	±6m	100x80m 8 000m <sup>2</sup>
<b>Temporary stockpiles at the open pits</b>			±2m	

## 1.2.2 Mining Method and Resource

The Project will involve the development of an open pit mine, processing plant and associated infrastructure. Sand, aggregate and alluvial diamonds are proposed to be mined in a phased open pit mining process, using a “truck and shovel” method. The planned open pit mine will comprise three distinct areas for the sand (main pit, north pit and east pit), and four areas for the aggregate (northern pit, central pit, south eastern pit and south western pit). Each area will be mined to an estimated maximum depth of 12 m, but may exceed this depth in certain areas. The entire application area could have the potential for diamond bearing gravels. The anticipated Life of Mine (LoM) is 30 years. Please refer to Appendix A for more information.

The mining method for each of the commodities is described in further detail below:

### 1.2.2.1 Sand Mining

Prior to commencement of sand mining, topsoil will be removed from the area demarcated for mining and stockpiled next to the pit for the purpose of rehabilitation. The area containing the sand deposit will be mined in portions of on average 6.8 ha per year (in most years, however, the area to be mined will not exceed 5 ha). The sand will be mined in benches and reject material will be backfilled into the previously mined out void as mining advances (roll-over rehabilitation). Open pit benches will be established with a maximum height of between 1.5 m to 3 m. The mined sand will either be screened in the pit or transported by truck or conveyer

to the washing plant. A total sand resource of 21 910 291 million m<sup>3</sup> is estimated for the application area, at an average depth of 10.64 m.

### **1.2.2.2 Aggregate Mining**

In the absence of sand, topsoil will be stripped to expose the aggregate and will be stockpiled adjacent to the pit. The area containing the aggregate resource will be mined in portions of on average 4.6 ha per year (in most years, however, the area to be mined will not exceed 4 ha). The aggregate will be extracted and crushed in the pit by a mobile crusher and reject material will be backfilled into the previously mined out void as mining advances. The total volume of fresh aggregate is calculated to be 9 565 043 million m<sup>3</sup>, at an average depth of 6.98 m, whilst the oxidised aggregate is estimated at 10 498 882 million m<sup>3</sup>, at an average depth of 7.67 m.

### **1.2.2.3 Alluvial Diamond Mining**

Once sand mining has commenced, the underlying gravel (potentially diamondiferous) will be exposed and Reverse Circulation boreholes will be drilled to ascertain gravel quality and the diamond potential. Where appropriate, the gravel will be excavated and screened. The oversize will be used as infill, the -2 mm will report to the sand mining operation, and the +2-32 mm fraction will be processed near the pit, to extract diamonds. The diamond potential exists across the entire Project area, but will initially be evaluated in the Main, Northern and East sand deposit area. Should diamond potential be established via the proposed drilling programme referred to above, the appropriate gravel fraction will be transported to an on-site processing plant to extract diamonds. The alluvial diamond mining process will commence as soon as the Mining Right is granted.

## **1.2.3 Mining Schedule and Project Phases**

The yearly open pit mining schedule for the sand and aggregate deposits are indicated on Figure 1-5. During Years 1 and 2, mining will consist only of excavating sand and aggregate at the locations as set out in the 30-year mining plan. The processes will include screening and crushing. Prospecting of diamonds will also occur during this time. The only infrastructure that will be constructed in the beginning of Year 1 will be roads, weighbridge, offices and a security check point. During this time other preparations may include the installation of the water supply line, electrical supply and cut-off trenches. The wash plant, drying plant, workshop, settling ponds and PCDs will be finalised for use in Year 3. Between Years 3 to 27, full production of sand and aggregate/gravel is expected during which the wash plant and drying plant will be in use. Depending on the outcome of the diamond prospecting, diamondiferous gravel may also be processed. During Years 27 to 30, production will decrease to meet closure targets at the end of Year 30. More information can be obtained in Appendix A.

Based on the above, the Project phases can be classified as follows:

**Construction Phase:** Years 1 and 2 can be classified as the construction phase for specialised sand, in conjunction with mining activities for screened products only;



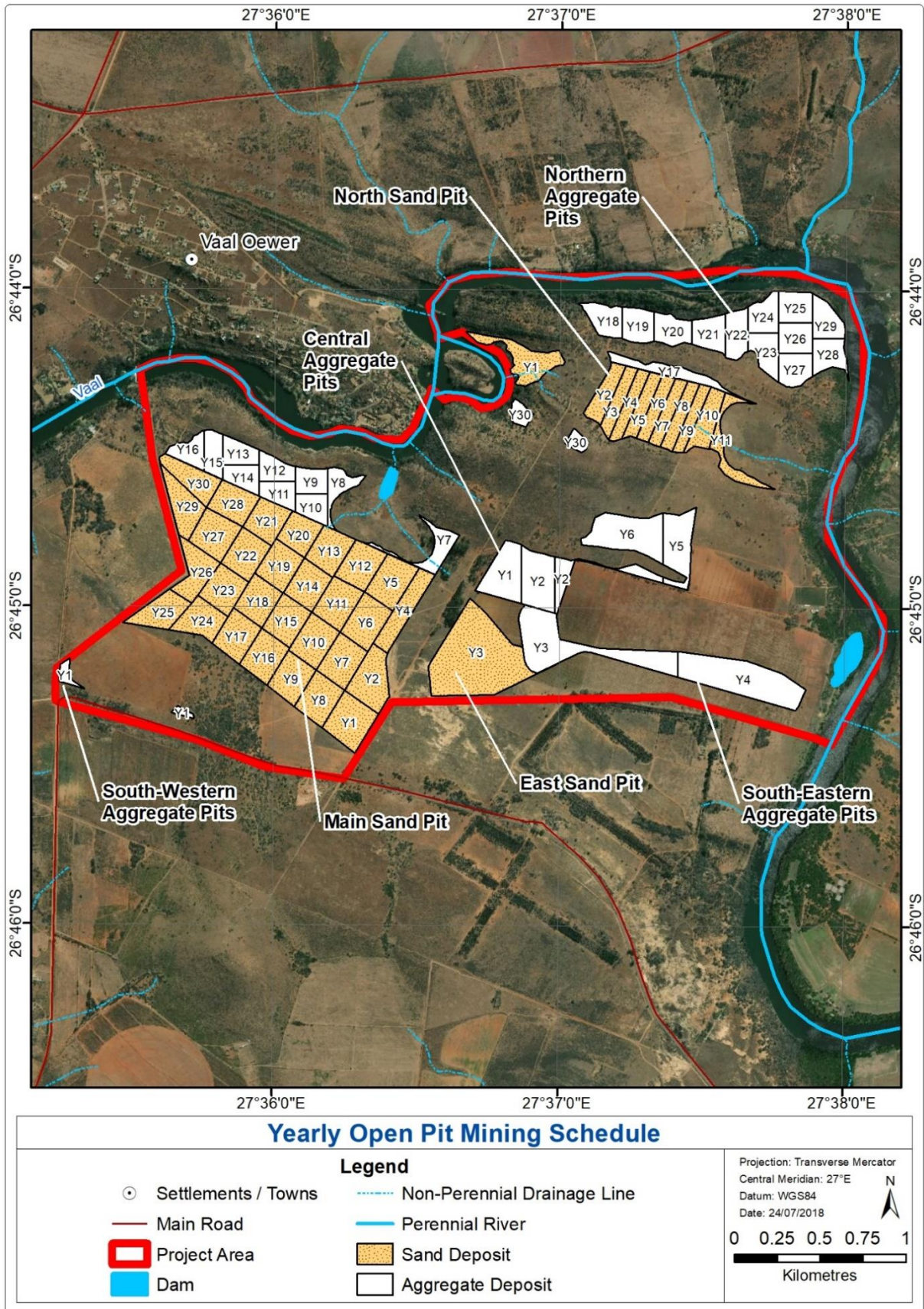

Figure 1-5: Yearly open pit mining schedule

- **Operational Phase:** Years 3 to 30 will be the operational phase; and
- **Closure Phase:** The last three years will involve the lowering of production to achieve closure objectives and is classified as the closure phase.

### 1.2.4 Employment and Operating Hours

Employment would constitute approximately 22 to 25 workers during the construction phase and approximately 48 to 50 full-time employees during the operational phase.

For mining activities, a 5.5 day work week with a 2 shift system is proposed. Operating hours would be from 06:00 to 18:00. For diamond sorting, a 6 day work week with a 2 shift system, operating 24 hours a day. The 24 hour shift for diamond sorting is being reconsidered as part of this Environmental Impact Assessment (EIA) phase.

### 1.2.5 Offices, Workshop and Change House

The offices, workshop, change house and dormitories will be established adjacent to the plant infrastructure. As per industry standard they will be portable in nature. The mine offices, workshops and change house will initially be in the form of portable containers or “Kwikspace” type facilities.

### 1.2.6 Sewage

Portable chemical toilets will be utilised and serviced regularly by external services providers during the construction and operational phases of the Project.

### 1.2.7 Waste and Storage of Dangerous Goods

General and hazardous industrial waste will be temporarily stored on-site in designated areas (waste/salvage yard), and disposed of at off-site permitted waste disposal facilities.

During the construction and operational phases, limited quantities of diesel fuel, oil and lubricants may be stored on-site. A maximum amount of 60 m<sup>3</sup> of diesel fuel may be stored in above ground diesel storage tanks with elevated bunded walls.

### 1.2.8 Roads

Existing farm roads will be utilised and may need to be widened to haul the resource from the pits to the plant. An access road will be established from the gate to the plant area and will be utilised throughout the life of the project. The Vaal Eden Road (S171), which forms the southern boundary of the project area, will be utilised during transporting of materials to and from site.



### 1.2.9 Post Mining Land Use

After mining, the closure objective is to reinstate the natural vegetation as far as possible for the game on the farm, and then later to develop the area as an eco-estate with residential and hospitality facilities on the banks of the Vaal River. The area is currently utilised as a game farm and for crop production.

## 1.3 Legislative Requirements and Guidelines

The following international and national legislative requirements and guidelines are relevant to the VIA study:

### 1.3.1 International

The European Landscape Convention (ELC) created by the Council of Europe, was the first international convention to focus exclusively on landscapes. The purpose of this convention is to promote effective management and planning of landscapes. It was signed by the United Kingdom government in 2006 and became binding from 2007. Public documents that explore the impacts of large scale developments, as defined in the ELC, on any landscape should take into account the effects of these developments. A landscape means “an area, as perceived by people, whose character is the result of the action and interaction of natural and/or human factors” i.e. the natural, visual and subjectively perceived landscape, (Contesse, 2011; European Landscape Convention, 2007).

There is no regional or local scale legislation pertaining to mining activities and Visual Impact Assessments (VIAs) exclusively but VIAs are relevant to the International Finance Corporation’s (IFC) Performance Standards and this will be treated as a best practice guideline.

IFC Performance Standard 3: Resource Efficiency and Pollution Prevention is applicable to the VIA. Performance Standard 3 recognises that increased economic activity and urbanisation often generate increased levels of pollution to air, water and land, and consume finite resources in a manner that may threaten people and the environment at the local, regional and global levels. For the purposes of this Performance Standard, the term ‘pollution’ is used to refer to both hazardous and non-hazardous chemical pollutants in the solid, liquid, or gaseous phases, and includes other components such as pests, pathogens, thermal discharge to water, GHG emissions, nuisance odours, noise, vibration, radiation, electromagnetic energy and the creation of potential visual impacts including light (IFC, 2012).

The Environmental, Health and Safety Guidelines for Mining therefore need to be considered (World Bank, 2007):

*“Mining operations, and in particular surface mining activities, may result in negative visual impacts to resources associated with other landscape uses such as recreation or tourism. Potential contributors to visual impacts include high walls, erosion, discoloured water, haul roads, waste dumps, slurry ponds, abandoned mining equipment and structures, garbage and refuse dumps, open pits, and deforestation. Mining operations should prevent and minimise*

*negative visual impacts through consultation with local communities about potential post-closure land-use, incorporating visual impact assessment into the mine reclamation process. Reclaimed lands should, to the extent feasible, conform to the visual aspects of the surrounding landscape. The reclamation design and procedures should take into consideration the proximity to public viewpoints and the visual impact within the context of the viewing distance. Mitigation measures may include strategic placement of screening materials including trees and use of appropriate plant species in the reclamation phase as well as modification of the placement of ancillary and access roads.”*

### 1.3.2 National

At a national level, the following legislative documents potentially apply to the VIA:

- Regulations in Chapter 5 (Integrated Environmental Management) of the NEMA and the Act in its entirety. The Act states that “the State must respect, protect, promote and fulfil the social, economic and environmental right of everyone...” Landscape is both moulded by, and moulds, social and environmental features;
- Section 23(1)(d) of the MPRDA, where it is mentioned that a mining right will be granted if “the mining will not result in unacceptable pollution, ecological degradation or damage to the environment”. Visual pollution is a form of environmental pollution and therefore needs to be considered under this section. Holders of rights granted in terms of the MPRDA must at all times give effect to the general objectives of integrated environmental management laid down in Chapter 5 of the NEMA. The Regulations promulgated in terms of the NEMA, with which holders of rights must comply, provide for the assessment and evaluation of potential impacts, and the setting of management plans to mitigate such impacts.
- The National Heritage Resources Act, 1999 (Act No. 25 of 1999) (NHRA) and related provincial regulations – in some instances there are policies or legislative documents that give rise to the protection of listed sites. The NHRA states that it aims to promote “good management of the national estate, and to enable and encourage communities to nurture and conserve their legacy so that it may be bequeathed for future generations”. A holistic landscape whose character is a result of the action and interaction and/or human factors has strong cultural associations as societies and the landscape in which they live are affected by one another in many ways; and
- Section 17 of the National Environmental Management: Protected Areas Act, 2003 (Act No. 57 of 2003) (NEM: PAA) sets out the purposes of the declaration of areas as protected areas which includes the protection of natural landscapes. Landscapes are defined by the natural, visual and subjectively perceived landscape; these aspects of a landscape are intertwined to form a holistic landscape context.

## 2 SCOPE OF WORK

The scope of work includes the following:

- Provide a baseline (pre-construction and mining) description of the visual and aesthetic characteristics of the area;
- Provide a visual and aesthetic evaluation of the Project; and
- Conduct an impact assessment to assess the visual impacts of the Project.

## 3 METHODOLOGY

### 3.1 Site Investigation

A site visit was undertaken on 1 August 2018. The purpose of the site visit was to investigate the visual and aesthetic characteristics of the landscape, as well as the sense of place of the area. Conditions during the site visit were noted to be dry, windy and dusty (Figure 3-1).



**Figure 3-1: Dusty conditions over the Project area (photograph taken from the southern boundary of the project area looking north)**

### 3.2 Baseline Visual and Aesthetic Environment

The purpose of the baseline is to provide a current and pre-mining description of the area in terms of the visual and aesthetic characteristics of the landscape. This was done by:

- Assessing aerial imagery of the area;
- Conducting a site visit;
- Assessing the topography of the study area by generating a Digital Elevation Model (DEM); and

- Reviewing literature on the Project and general area.

### 3.3 Visual and Aesthetic Evaluation

The following criteria was used in the visual and aesthetic evaluation:

#### 3.3.1 Visibility and Visual Exposure

The visibility of the Project was determined through a viewshed analysis. A viewshed indicates areas within the landscape from where the Project will and will not be visible. A DEM for the study area was generated from 5 m contour elevation data, which was obtained from the 1:50 000 topographical dataset of South Africa. The infrastructure heights from Table 1-1 together with the DEM, were input into the viewshed analysis tool in ArcMap 10.2, in order to generate the viewshed.

The visual exposure is the relative visibility of a development or feature in a landscape (Oberholzer, 2005). The visual exposure decreases as the distance between the development/feature and visual receptor increases. The visual exposure for the Project was determined to be:

- High – between 0 to 2 km from the Project area;
- Medium – between 2 to 4 km from the Project area; and
- Low – between 4 to 5 km from the Project area.

#### 3.3.2 Visual/Scenic Quality

The visual quality is high when:

- The landscape offers dramatic, rugged topography and/or visually appealing water forms are present;
- Pleasing, dramatic or vivid patterns and combinations of landscape features and vegetation are found;
- The landscape is without visually intrusive or polluting urban, agriculture or industrial development (i.e.it reveals a high degree of integrity); and/or
- Outstanding or evocative features and landmarks are present; and
- The landscape/townscape is able to convey meaning.

#### 3.3.3 Visual Absorption Capacity

The Visual Absorption Capacity (VAC) is the potential of the landscape to conceal the proposed development as a result of topography, vegetation or synthetic features (Oberholzer, 2005). The criteria used to assess the VAC is indicated in Table 3-1.

**Table 3-1: Visual absorption capacity criteria**

High	Moderate	Low
<p>The area is effectively able to screen visual impacts:</p> <ul style="list-style-type: none"> <li>• Undulating or mountainous topography and relief;</li> <li>• Good screening vegetation (high and dense);</li> <li>• Is highly urbanised in character; and</li> <li>• Existing development is of a scale and density to absorb the visual impact.</li> </ul>	<p>The area is partially able to screen visual impacts:</p> <ul style="list-style-type: none"> <li>• Moderately undulating topography and relief;</li> <li>• Some or partial screening vegetation;</li> <li>• A relatively urbanised character; and</li> <li>• Existing development is of a scale and density to absorb the visual impact to some extent.</li> </ul>	<p>The area is not able to screen the visual impacts:</p> <ul style="list-style-type: none"> <li>• A flat topography;</li> <li>• Low growing or sparse vegetation;</li> <li>• Is not urbanised; and</li> <li>• Existing development is not of a scale and density to absorb the visual impact to some extent.</li> </ul>

### 3.3.4 Visual Intrusion

Visual intrusion is the level of compatibility or congruence of a project with the particular qualities of the area, or its 'sense of place' (Oberholzer, 2005). The criteria used to assess the visual intrusion is indicated in Table 3-2.

**Table 3-2: Visual intrusion criteria**

High	Moderate	Low
<p>The development /activity results in a noticeable change or is discordant with the surroundings:</p> <ul style="list-style-type: none"> <li>• Is not consistent with the existing land use of the area;</li> <li>• Is not sensitive to the natural environment;</li> <li>• Is very different to the urban texture and layout;</li> <li>• The buildings and structures are not congruent / sensitive to the existing architecture / buildings; and</li> <li>• The scale and size of the activities are different to nearby existing activities.</li> </ul>	<p>The development/activity partially fits into the surroundings but is clearly noticeable:</p> <ul style="list-style-type: none"> <li>• Is moderately consistent with the existing land use of the area;</li> <li>• Is moderately sensitive to the natural environment;</li> <li>• Is moderately consistent with the urban texture and layout;</li> <li>• The buildings and structures are moderately congruent / sensitive to the existing architecture / buildings; and</li> <li>• The scale and size of the activities are moderately similar to nearby existing activities.</li> </ul>	<p>The development/activity results in a minimal change to the surroundings and blends in well:</p> <ul style="list-style-type: none"> <li>• Is consistent with the existing land use of the area;</li> <li>• Is highly sensitive to the natural environment;</li> <li>• Is consistent with the urban texture and layout;</li> <li>• The buildings and structures are congruent / sensitive to the existing architecture / buildings; and</li> <li>• The scale and size of the activities are similar to nearby existing activities.</li> </ul>

### 3.3.5 Viewer Sensitivity

Visual receptors inform the viewer sensitivity. The criteria used to assess the viewer sensitivity is indicated in Table 3-3.

**Table 3-3: Viewer sensitivity criteria**

High	Moderate	Low
<ul style="list-style-type: none"> <li>• Residential areas;</li> <li>• Lodges, resorts and hotels;</li> <li>• Nature reserves; and</li> <li>• Scenic routes / trails.</li> </ul>	<ul style="list-style-type: none"> <li>• Sporting and recreational areas; and</li> <li>• Places of work.</li> </ul>	<ul style="list-style-type: none"> <li>• Industrial areas;</li> <li>• Active mining areas; and</li> <li>• Severely degraded areas.</li> </ul>

## 3.4 Impact Assessment

The impact assessment was carried out by assessing and comparing the baseline (pre-mining) visual landscape characteristics to the mining landscape during the different phases of the Project. The impacts are assessed in terms of the proposed Projects visibility, visual exposure, visual intrusion, alteration to the sense of place, amongst others. The impact assessment methodology is discussed below.

The impact significance rating process serves to highlight the critical impacts requiring consideration in the management and approval process.

The impact significance rating system is presented in Table 3-4, Table 3-5 and Table 3-6, and involves three parts:

- **Part A:** Define the impact consequence using the three primary impact characteristics of magnitude, spatial scale/population and duration;
- **Part B:** Use the matrix to determine a rating for impact consequence based on the definitions identified in Part A; and
- **Part C:** Use the matrix to determine the impact significance rating, which is a function of the impact consequence rating (from **Part B**) and the probability of occurrence.

These are discussed in further detail below.

### 3.4.1 Part A: Defining Consequence in Terms of Magnitude, Duration and Spatial Scale

Table 3-4 is used to determine the impact consequence characteristics for magnitude, spatial scale/population and duration.

**Table 3-4: Consequence rating definitions**

<b>IMPACT CHARACTERISTICS</b>	<b>DEFINITION</b>	<b>CRITERIA</b>
<b>Magnitude</b>	Major -	Substantial deterioration or harm to receptors; receiving environment has an inherent value to stakeholders; receptors of impact are of conservation importance; or identified threshold often exceeded
	Moderate -	Moderate/measurable deterioration or harm to receptors; receiving environment moderately sensitive; or identified threshold occasionally exceeded
	Minor -	Minor deterioration (nuisance or minor deterioration) or harm to receptors; change to receiving environment not measurable; or identified threshold never exceeded
	Minor +	Minor improvement; change not measurable; or threshold never exceeded
	Moderate +	Moderate improvement; within or better than the threshold; or no observed reaction
	Major +	Substantial improvement; within or better than the threshold; or favourable publicity
<b>Spatial scale or population</b>	Site or local	Site specific or confined to the immediate project area (within the proposed MRA)
	Regional	Beyond the project area
	National/ International	Nationally or beyond
<b>Duration</b>	Short term	Up to 18 months
	Medium term	18 months to 5 years
	Long term	Longer than 5 years

### 3.4.2 Part B: Determining the Consequence Rating

Once the impact consequence characteristics have been determined from Table 3-4, they are applied to Table 3-5 to obtain the consequence rating.



**Table 3-5: Consequence rating methodology**

		SPATIAL SCALE/ POPULATION			
		Site Local	or	Regional	National/ international
MAGNITUDE					
Minor	DURATION	Long term	Medium	Medium	High
		Medium term	Low	Low	Medium
		Short term	Low	Low	Medium
Moderate	DURATION	Long term	Medium	High	High
		Medium term	Medium	Medium	High
		Short term	Low	Medium	Medium
Major	DURATION	Long term	High	High	High
		Medium term	Medium	Medium	High
		Short term	Medium	Medium	High

### 3.4.3 Part C: Determining Significance Rating

The probability of the impact occurring is assessed as either being definite, possible or unlikely, and is selected in Table 3-6. The consequence rating determined from Table 3-5, is then used to obtain the significance of the impact in Table 3-6.

**Table 3-6: Significance rating methodology**

		CONSEQUENCE		
		Low	Medium	High
PROBABILITY (of exposure to impacts)	Definite	Medium	Medium	High
	Possible	Low	Medium	High
	Unlikely	Low	Low	Medium

The significance rating of the impact is determined prior to mitigation (without mitigation), as well as after mitigation measures have been implemented.

## 4 ASSUMPTION AND LIMITATIONS

The following are assumptions and limitations of the study:

- The viewsheds were modelled using fairly coarse scale 5 m contour intervals which were the best available contours within a 5 km radius of the Project area. Due to the coarse scale contours used, there could thus be areas that may or may not be visible; and



- The viewshed modelling only considers the topography of the area and can therefore be considered a worst-case scenario.

## 5 BASELINE VISUAL AND AESTHETIC ENVIRONMENT

### 5.1 Topography

The topography of an area in which a project is located, plays an important role in the visibility of a project. For instance, in mountainous areas, a project may be concealed within a valley and not be visible to visual receptors. However, if a project is developed on top of a mountain, or in an open flat area, it may be visible to many visual receptors. Figure 5-1 demonstrates the role topography in the visibility of a project.

The topography of the study area can be described as undulating. Elevation varies from 1 600 metres above mean sea level (mamsl) along an elevated area towards the north of the study area, to 1 401 mamsl at the Vaal River. Two parallel ridges, running in a north-west to south-east direction, are located towards the north-east of the Project area. A hill reaching a height of 1 520 mamsl is located immediately to the south of the Project area. The three mine infrastructure alternatives are located in a shallow valley between the above-mentioned ridges and hill. Figure 5-2 indicates the topography of the study area.

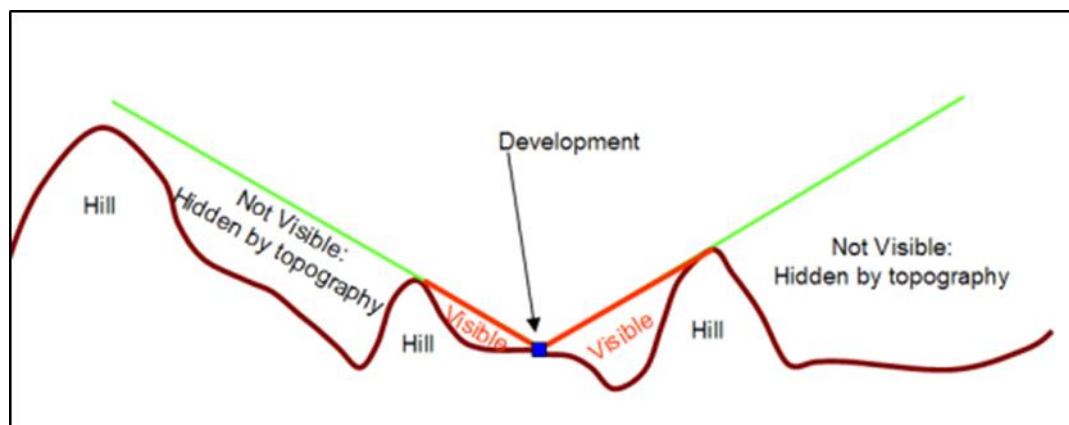

Figure 5-1: The role of topography in the visibility of a project

### 5.2 Land Cover and Use

Similar to topography, the land cover of an area plays an important role in the visibility of a project. Tall dense vegetation can conceal a project from visual receptors, while projects located in open areas consisting of grassland vegetation, are likely to be more visible to receptors.

The land cover of the study area consists mostly of grassland and cultivated land (Figure 5-3). Thicker riverine vegetation occurs along the banks of the Vaal River. The Project area is currently used for crop and game farming. Directly to the north of the Project, a housing development is located at Vaal Oewer on an elevated ridge. Agricultural and housing

developments are located along the Vaal River towards the north-west and west of the Project near Lindequesdrif. Guesthouses, lodges and resorts are fairly common in the area, as the Vaal River is a popular weekend and holiday destination, offering recreational activities such as boat cruisers, water sports and angling. Sand mining activities are evident directly south, south-east and west of the Project. Active sand mines occur on the adjacent properties to the Project and include Sweet Sensations Vaal Sand mine to the west, and Tja Naledi Beafase Investment Holdings to the south.

### 5.3 Landscape Characterisation

From the above description, the study area can be broadly divided into three main categories:

- Agricultural areas – crop and livestock agriculture are the dominant land use in the area;
- Agricultural holdings, residential/housing and accommodation – housing developments and places offering accommodation, occur mostly along the Vaal River; and
- Sand mining activities.

### 5.4 Visual Receptors

The following visual receptors have been identified within a 5 km radius of the Project area:

- Agricultural holdings and residential/housing developments, particularly those located along the Vaal River to the north and west of the Project;
- Places providing accommodation (guesthouses, resorts, lodges and campsites), which mostly occur along the Vaal River;
- Conference centres;
- Farmhouses; and
- Motorists on roads within the surrounding area.

### 5.5 Sense of Place

Sense of place is the unique value that is allocated to a specific place or area through the cognitive experience of the user or viewer. According to Lynch (1992), sense of place “is the extent to which a person can recognise or recall a place as being distinct from other places – as having a vivid, unique, or at least particular, character of its own”.

Crop and livestock farming areas, which dominate the landscape, largely evoke a feeling of a farming community, while along the Vaal River, where residential houses and places of accommodation are located, a tranquil sense of place is evoked. The sand mining areas evoke an open and barren sense of place, which is typically associated with open pit mining activities.

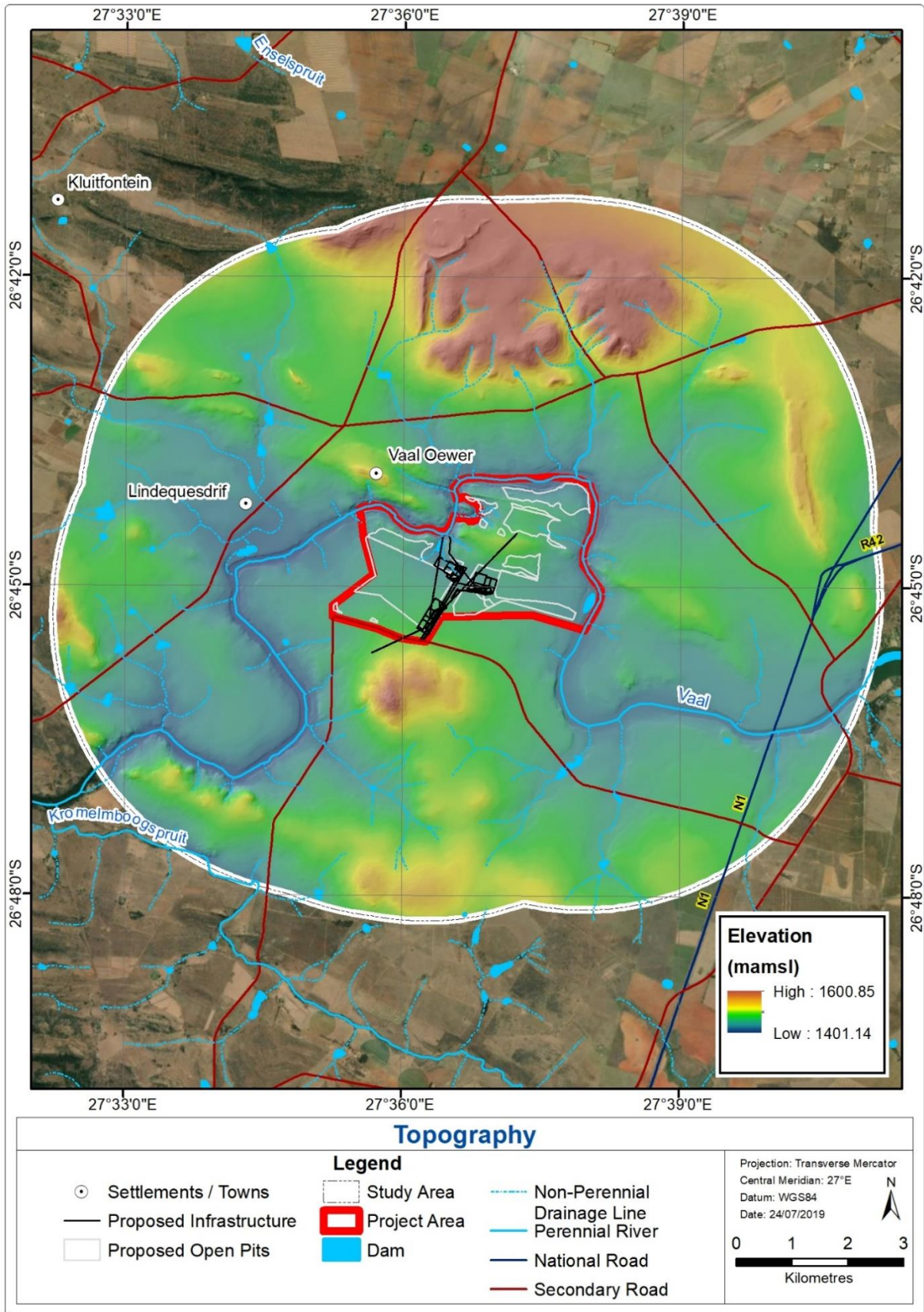

Figure 5-2: Topography of the study area



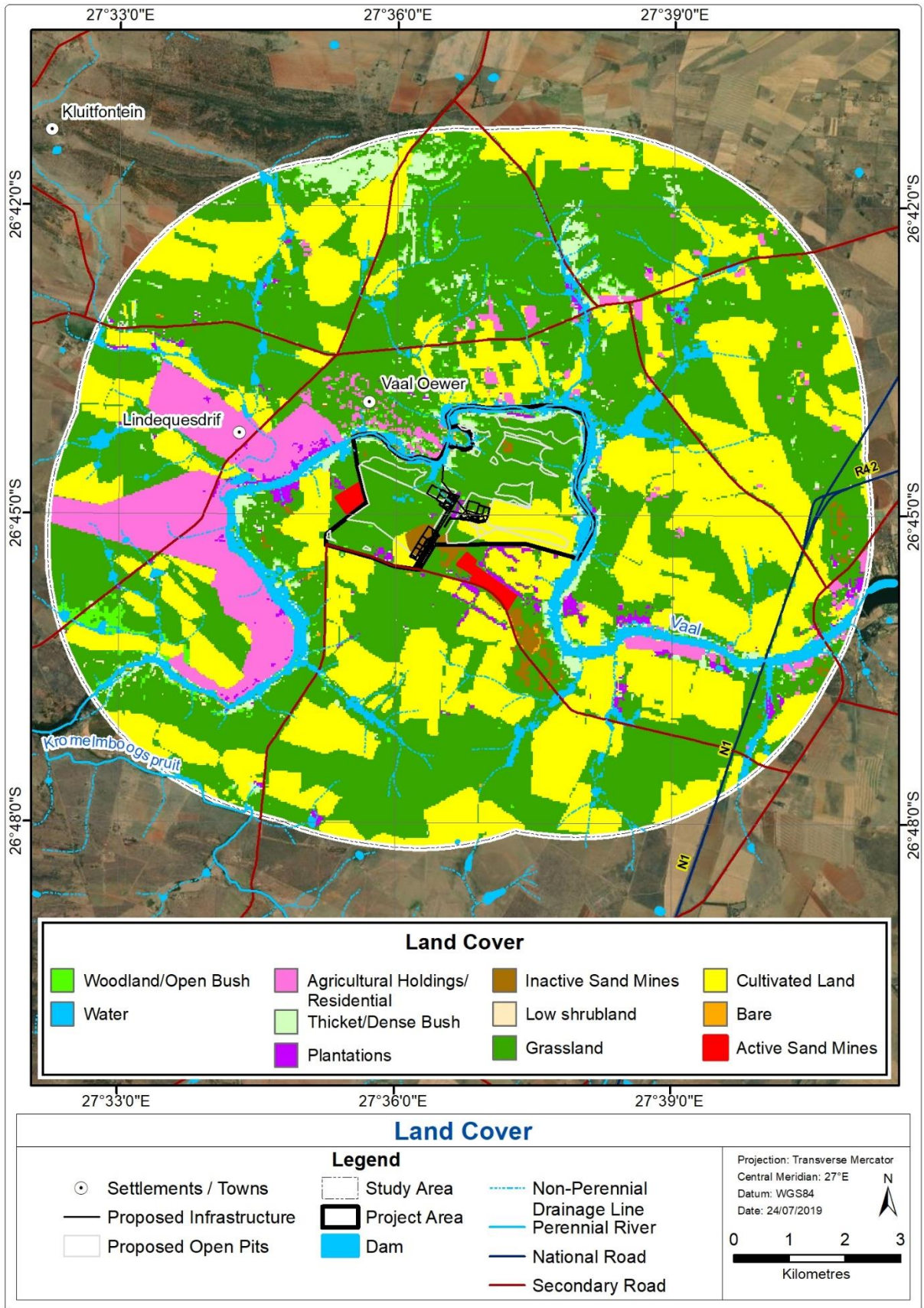

Figure 5-3: Land cover and use within the study area

## 5.6 Protected Areas and Cultural and Heritage Landscapes

No protected areas fall within the study area. In terms of heritage, the Vredefort Dome World Heritage Site is situated 10 km south-west of the study area, and therefore falls outside of the zone of potential influence for this study. In the latter part of the 19th Century, the Vredefort Dome was recognized as being geologically unusual and has been the focus of geological study since that time. As a result of the almost unique geology, excellent exposure of the rocks, scenic surrounds, and its great scientific value, a portion of the collar of the Vredefort Dome has been declared a World Heritage Site.

According to the Scoping Report (Shango, 2018), eight cultural and heritage sites were identified within the Project area and are provided in Table 5-1.

**Table 5-1: Cultural and heritage sites within the Project area**

Site	Coordinates	Type	Significance
1	26°44.386'S 27°36.652'E	SA War redoubt	High
2	26°44.487'S 27°36.813'E	Two circular enclosure	Low
3	26°44.476'S 27°36.770'E	Circular enclosure	Low
4	26°44.885'S 27°37.270'E	Cemetery	High
5	26°44.133'S 27°37.000'E	Square enclosure	Low
6	26°44.129'S 27°36.948'E	Circular enclosure	Low
7	26°44.098'S 27°36.775'E	Circular enclosure	Low
8	26°45.001'S 27°37.898'E	Modern house	Low

## 6 VISUAL AND AESTHETIC EVALUATION

### 6.1 Visibility and Visual Exposure

Viewshed analysis modelling was undertaken to determine the visibility of the three mine infrastructure alternatives on the surrounding landscape. The visibility and affected visual receptors for the three alternatives is indicated on Figure 6-2, Figure 6-3 and Figure 6-4. The visual exposure of the Project on visual receptors is as follows:

- High – between 0 to 2 km from the Project area;
- Medium – between 2 to 4 km from the Project area; and
- Low – between 4 to 5 km from the Project area.

For all three alternatives, the Project will have a high visual exposure on visual receptors located at Vaal Oewer and Lindequesdrif, as well for other receptors located within a 2 km

buffer. This includes a campsite, conference centre, resorts, lodges, and a number of houses. Figure 6-1 provides a schematic from Vaal Oewer looking over the Project area in a south-easterly direction.

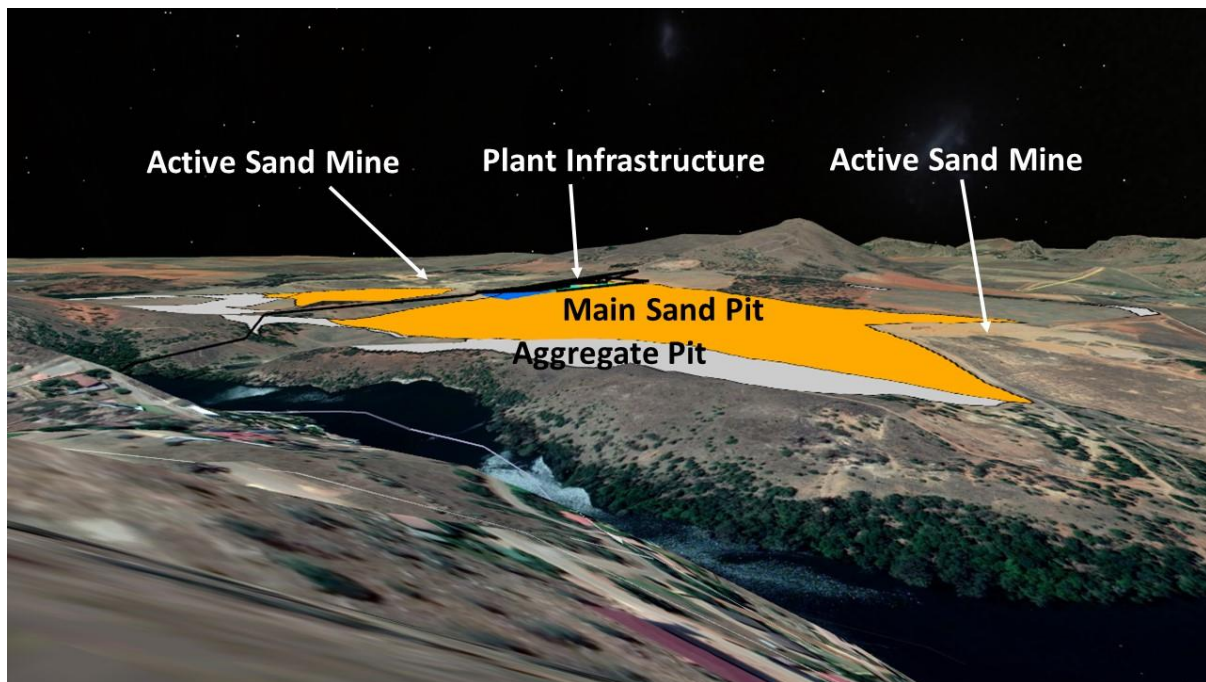

**Figure 6-1: Schematic from Vaal Oewer looking over the Project area in a south-easterly direction**

Infrastructure alternative 1 has the largest visible area within the study area, affecting the most visual receptors. This is followed by alternative 2, and then alternative 3. The reason for alternative 1 having the largest visible area, is because it is located on higher ground than the other alternatives. A summary of the visible areas and affected visual receptors for the three alternatives is provided in Table 6-1. As can be observed in Table 6-1, alternative 2 and 3 do not significantly affect a much larger visible area, or a significantly greater number of visual receptors than alternative 1.

**Table 6-1: Summary of the visible areas and affected visual receptors for the three infrastructure alternatives**

Infrastructure Alternative	Visible Area (km <sup>2</sup> )	No. of Visual Receptors in the Visible Area	Length of Road in the Visible Area (km)
Alternative 1	107.45	928	169
Alternative 2	104.37	878	162.9
Alternative 3	103.86	870	162.4



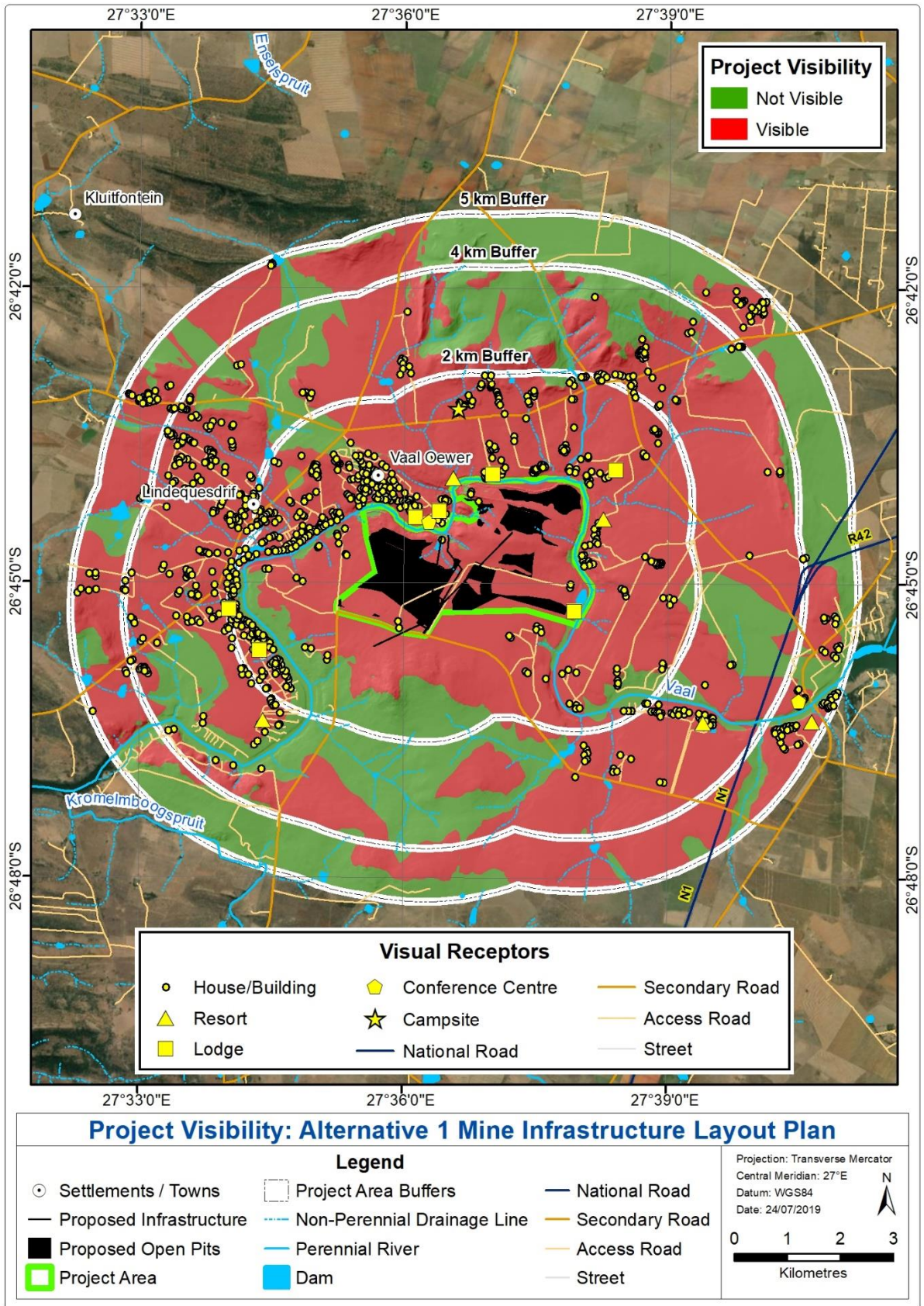

Figure 6-2: Project visibility for the alternative 1 mine infrastructure layout plan



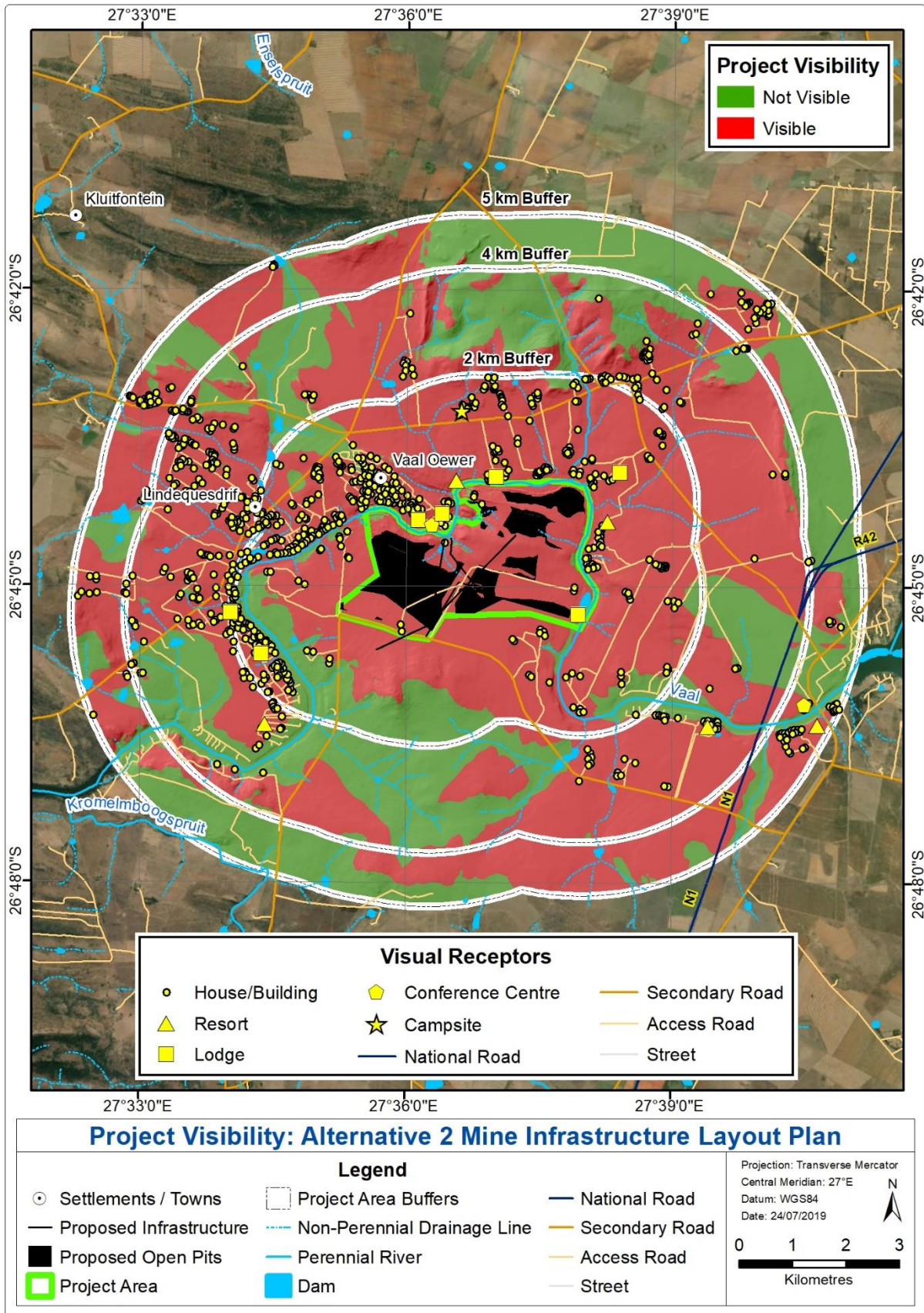

Figure 6-3: Project visibility for the alternative 2 mine infrastructure layout plan



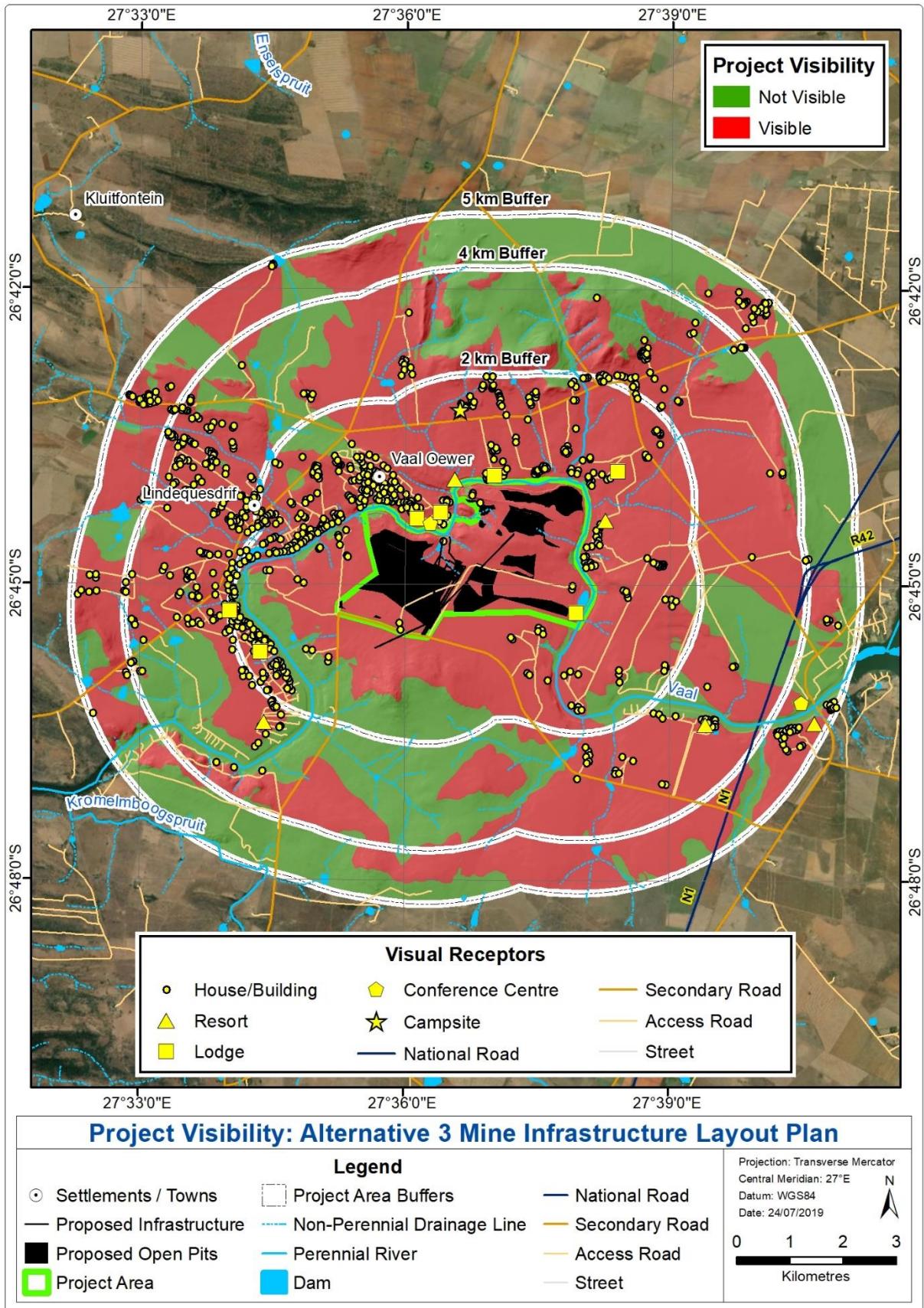

Figure 6-4: Project visibility for the alternative 3 mine infrastructure layout plan

## 6.2 Visual/Scenic Quality

Studies in perceptual psychology have shown that humans prefer landscapes with higher complexity and landscape quality can be said to increase when:

- Natural landscape increases and man-made landscape decreases;
- Well-preserved, compatible man-made structures are present;
- Diverse or vivid patterns of grasslands and trees occur;
- Water forms are present;
- Topographic ruggedness and relative relief increases; and
- Where land use compatibility increases (Crawford, 1994, Arriaza, 2004).

Greater aesthetic value is also attached to places where:

- Rare, distinguished or uncommon features are present;
- The landscape/townscape evokes particularly strong responses in community members or visitors;
- The landscape/townscape has existing, long-standing meaning or significance to a particular group; and
- Landmark quality features are present. (Ramsay, 1993).

The visual quality was determined to be high close to the Vaal River, and medium further back from the river, where grassland and cultivated land dominate the landscape. The inactive and active sand mining areas have a low visual quality.

## 6.3 Visual Absorption Capacity

As previously mentioned, the VAC is the potential of the landscape to conceal the proposed development as a result of topography, vegetation or synthetic features (Oberholzer, 2005). Due to the mine infrastructure and pits being mostly located in grassland and moderately undulating topography, the VAC of the landscape in which the Project area is located, has a moderate potential to conceal the Project.

## 6.4 Visual Intrusion

Visual intrusion is the level of compatibility or congruence of a project with the particular qualities of the area, or its 'sense of place' (Oberholzer, 2005). The proposed Project will partially fit in with the existing active sand mines in the area (Figure 5-3 and Figure 6-1). However, open pit mining is likely to take place on a bigger scale than what is currently being undertaken, and will result in a clearly noticeable mining area. For these reasons, the Project will have a moderate visual intrusion on the landscape.

## 6.5 Viewer Sensitivity

The viewer sensitivity is summarised in Table 6-2.

**Table 6-2: Summary of the viewer sensitivity of the Project**

Visual Receptor	Comment	Rating
Houses	People living in the houses in the area have generally moved away from larger urban areas to live in a quieter and more scenic area. Many of the homes in the area are holiday and weekend homes.	High
Resorts, lodges, conference centres and campsites	The Vaal River is a short drive from Johannesburg and Pretoria and is a popular weekend and holiday destination. The Vaal River provides recreational activities such as water sports, angling and boat cruisers. People also use the accommodation in the area to attend functions such as conferences and weddings.	High
Motorists on roads	From the N1 highway, the Project may potentially be visible for short periods of time at a low visual exposure. The visibility of the Project will therefore be low to negligible from the N1. The other significant road in the area, is the Potchefstroom road to the north of the Project. The Project is visible from this road, and the road falls within the outer area of the high visual exposure zone. The vegetation along the sides of the road will to some degree conceal the proposed Project from the views of motorists.	Moderate

## 7 IMPACT ASSESSMENT

### 7.1 Project Phase Description

The potential impacts during the different phases of the project are discussed below.

#### 7.1.1 Construction Phase

During the construction phase, vegetation clearance and topsoil stripping at the plant and open pits will take place. The roads in the area may also need to be widened. The plant and associated infrastructure will begin to be erected.

The construction phase will result in areas being cleared, the presence of heavy machinery in the area and the generation of dust.

#### 7.1.2 Operational and Rehabilitation Phase

During the operational phase, open pit mining and rehabilitation will take place concurrently. As each open pit is created, the reject material will be placed in the previous mined out pit, followed by the subsoils and topsoils. The mined sand will either be screened in the pit or transported by truck or conveyer to the washing plant. In the absence of sand, topsoil will be stripped to expose the aggregate and will be stockpiled adjacent to the pit. The aggregate will be extracted and crushed in the pit by a mobile crusher and reject material will be backfilled into the previously mined out void as mining advances.

The operational phase will result in the presence of heavy machinery and dust. The plant and associated infrastructure will be fully erected during the operational phase, with highest infrastructure being the silos, reaching a height of 25.5 m above ground. Night-time lighting in the area will increase, particularly at the plant.

#### 7.1.3 Post Mine Closure

After mining, the closure objective is to develop the area as an eco-estate with residential and hospitality facilities on the banks of the Vaal River. This phase of the project will not be assessed, as it is understood that an environmental authorisation has been granted for the eco-estate.

### 7.2 Cumulative Impacts

Cumulative impacts result from the incremental impact of proposed activities on a common resource when added to the impacts of other past, present or reasonably foreseeable future activities. Cumulative impacts can occur from the collective impacts of individual minor actions over a period of time and can include both direct and indirect impacts.

The proposed Project will cumulatively add to the historical and active sand mining in the area. The proposed Project is likely to further reduce the visual quality of the area, through the

removal of vegetation, additional movement of heavy machinery in the area, and the generation of additional dust. The visual quality, will however, be improved during the post-closure phase, when the eco-state is developed.

### **7.3 Impact Assessment and Mitigation Measures**

The pre- and post-mitigation impact assessment for the construction, operational/rehabilitation and post mine closure phases, as well as for the cumulative impacts, are provided in Table 7-1.



**Table 7-1: Impact assessment**

Activities	Impact Description	PRE-MITIGATION						Mitigation Measures / Recommendations	POST-MITIGATION					
		Magnitude	Duration	Spatial Scale	Consequence	Probability	SIGNIFICANCE		Magnitude	Duration	Spatial Scale	Consequence	Probability	SIGNIFICANCE
<b>CONSTRUCTION PHASE</b>														
Removal of vegetation and the stripping and stockpiling of topsoils	Creation of a barren landscape and the generation of dust.	Major -	Long Term > 5 years	Regional	High	Definite	High	<ul style="list-style-type: none"> <li>• Clearance of vegetation must be limited as far as possible to only necessary areas;</li> <li>• Tall dense vegetation that can conceal the Project from sensitive visual receptors, should as far as possible be left in place; and</li> <li>• Dust suppression measures should be implemented to limit the generation of dust.</li> </ul>	Moderate -	Long Term > 5 years	Site or Local	Medium	Possible	Medium

Activities	Impact Description	PRE-MITIGATION						Mitigation Measures / Recommendations	POST-MITIGATION					
		Magnitude	Duration	Spatial Scale	Consequence	Probability	SIGNIFICANCE		Magnitude	Duration	Spatial Scale	Consequence	Probability	SIGNIFICANCE
Vehicular and heavy machinery movement	The movement of vehicles and heavy machinery during the construction phase is likely to generate dust and create visual disturbance to surrounding visual receptors.	Major -	Long Term > 5 years	Site or Local	High	Definite	High	<ul style="list-style-type: none"> <li>Tall vegetation along the sides of the roads at the site should not be removed, in order to conceal vehicular movement; and</li> <li>Dust suppression measures should be implemented to limit the generation of dust along roads.</li> </ul>	Moderate -	Medium Term > 18 months < 5 years	Site or Local	Medium	Possible	Medium
Erection of mine infrastructure	The erection of mine infrastructure (plant, workshop, etc.) will visually intrude on the surrounding landscape.	Major -	Long Term > 5 years	Site or Local	High	Definite	High	<ul style="list-style-type: none"> <li>The height of the proposed mine infrastructure should be limited as far as possible;</li> <li>Tall dense vegetation that can conceal the Project from sensitive visual receptors, should as far as possible be left in place; and</li> <li>The silos which will be the highest infrastructure should be painted earthy colours to blend into the landscape.</li> </ul>	Moderate -	Long Term > 5 years	Site or Local	Medium	Possible	Medium

Activities	Impact Description	PRE-MITIGATION						Mitigation Measures / Recommendations	POST-MITIGATION					
		Magnitude	Duration	Spatial Scale	Consequence	Probability	SIGNIFICANCE		Magnitude	Duration	Spatial Scale	Consequence	Probability	SIGNIFICANCE
Lighting from the mine at night	Lighting from the mine impacting on visual receptors.	Moderate -	Long Term > 5 years	Site or Local	Medium	Definite	Medium	Down lighting and lighting shields should be used as far as possible.	Minor -	Long Term > 5 years	Site or Local	Medium	Possible	Medium
<b>OPERATIONAL AND REHABILITATION PHASE</b>														
Open pit mining	Open pit mining will result in open barren areas and will visually intrude on the surrounding landscape. Stripped topsoils and mined resource will be temporarily stockpiled at the pits.  Dust will be generated during mining activities.	Major +	Long Term > 5 years	Regional	High	Definite	High	<ul style="list-style-type: none"> <li>The mined-out areas should be rehabilitated to a pre-mining topography;</li> <li>Mined out areas should be vegetated with indigenous species as soon as possible. This will to a degree, mitigate the visual intrusion of these areas on surrounding visual receptors;</li> <li>Dust suppression measures should be implemented to limit the generation of dust; and</li> <li>The height of dumps should be limited as far as possible.</li> </ul>	Moderate -	Long Term > 5 years	Site or Local	Medium	Possible	Medium



Activities	Impact Description	PRE-MITIGATION						Mitigation Measures / Recommendations	POST-MITIGATION					
		Magnitude	Duration	Spatial Scale	Consequence	Probability	SIGNIFICANCE		Magnitude	Duration	Spatial Scale	Consequence	Probability	SIGNIFICANCE
Vehicular and heavy machinery movement	The movement of vehicles and heavy machinery during the operational phase is likely to create a visual disturbance to surrounding visual receptors.  Dust generated along roads is likely.	Major -	Long Term > 5 years	Regional	High	Definite	High	<ul style="list-style-type: none"> <li>Tall vegetation along the sides of the roads at the site should not be removed, in order to conceal vehicular movement; and</li> <li>Dust suppression measures should be implemented to limit the generation of dust along roads.</li> </ul>	Moderate -	Long Term > 5 years	Site or Local	Medium	Definite	Medium
Lighting from the mine at night	Lighting from the mine impacting on visual receptors	Moderate -	Long Term > 5 years	Site or Local	Medium	Definite	Medium	Down lighting and lighting shields should be used as far as possible.	Moderate -	Medium Term > 18 months < 5 years	Site or Local	Medium	Possible	Medium
Erected mine infrastructure	The erection of mine infrastructure (plant, workshop, etc.) will visually intrude on the surrounding landscape.	Major -	Long Term > 5 years	Site or Local	High	Definite	High	The silos should be painted earthy colours to blend into the landscape	Moderate -	Medium Term > 18 months < 5 years	Site or Local	Medium	Possible	Medium

## 8 CONCLUSION AND RECOMMENDATIONS

Although the Project is located in a historical and active sand mining area, the scale of the Project in comparison to other sand mining in the area, moderate VAC of the landscape to conceal the Project, high visual quality along the Vaal River, and high viewer sensitivity of houses and places of accommodation within a 2 km buffer of the Project, will result in an overall high visual impact. The main sources of visual impact will be the transformation of grassland and agricultural land to open barren areas through open pit mining, generation of dust from exposed areas, increased heavy machinery and vehicular movement, and the erection of mine infrastructure. This, however, can be mitigated to an overall medium visual impact, by ensuring that dust suppression measures are strictly and timeously adhered to, concurrent rehabilitation takes place through re-shaping and re-vegetation, down lighting and shielding is used, and ensuring that mine infrastructure blends into the surrounding landscape through careful positioning and painting of infrastructure.

From a visual perspective, infrastructure alternative 1 has the largest visible area within the study area, affecting the most visual receptors. This is followed by alternative 2, and then alternative 3. The reason for alternative 1 having the largest visible area, is because it is located on higher ground than the other alternatives. However, as indicated in Table 6-1, alternative 2 and 3 do not significantly affect a much larger visible area, or a significantly greater number of visual receptors than alternative 1.

## 9 REFERENCES

- Arriaza, M. 2004. Assessing Visual Quality in Rural Landscapes. *Landscape and Urban Planning*, Vol. 69, Issue 1 pg 115-125, 15 July 2004.
- Cornell, D.H., Thomas, R.J., Moen, H.F.G, Reid, D.L., Moore J.M. and Gibson, R.L. 2006. The Namaqua-Natal Province. In: Johnson, M.R., Anhaeusser, C.R. and Thomas, R.J. (Eds.), *The Geology of South Africa*. Geological Society of South Africa, Council for Geoscience, Pretoria, 325-380.
- Crawford, D. 1994. Using remotely sensed data in landscape visual quality assessment, *Landscape and Urban Planning*. 30: 17-81.
- Lynch, K. 1992. *Good City Form*, The MIT Press, London. p131
- Oberholzer, B. 2005. *Guideline for involving visual and aesthetic specialists in EIA processes: Edition 1*. CSIR Report No ENV-S-C 2005 053 F. Republic of South Africa, Provincial Government of the Western Cape, Department of Environmental Affairs & Development Planning, Cape Town.
- Ramsay, J. 1993. Identification and assessment of aesthetic values in two Victorian forest regions. More than meets the eye: identifying and assessing aesthetic value. Report of the Aesthetic Value Workshop held at the University of Melbourne.
- Shango. 2018. Final Scoping Report. Pure Source Mine.

## **APPENDIX A: PURE SOURCE MINE INFORMATION PROVIDED BY SKETS**



Skets Architects, Planning &  
Environmental Consulting cc.  
Reg. no: 2010/034929/23

P.O. Box 14956  
Zuurfontein  
1912  
Fax: 086 520 4677  
Tel: 076 169 1435  
Email: [mader@skets.co.za](mailto:mader@skets.co.za)

**CONTACT PERSON:**

Mr. Mader van den Berg on behalf of Skets Architects, Planning & Environmental Consulting cc acting as an external consultant on behalf of Monte Cristo Commercial Park and Pure Source Mine.

**ADDRESSED TO:**

Directors of Monte Cristo Commercial Park

29 May 2019 (version 6)

**COLLATED INFORMATION REQUIRED BY VISUAL IMPACT SPECIALIST FOR THE  
COMPILATION OF A VISUAL IMPACT ASSESSMENT REPORT PERTAINING TO THE  
PROPOSED MINING ACTIVITY ON THE FARM GOOSEBAY, FREE STATE PROVINCE.**

Dear Adv van Wyk

Please find the collated information with regards to all proposed infrastructure as part of the processes for mining sand, aggregate and alluvial diamonds.

## **1 PRODUCTS TO BE MINED OVER 30 YEARS**

The main products from the mining operation will be:

1. Different grades of sand for construction, refractory, recreational and glass industries;
2. Aggregates for civil construction industries, in particular G4-G7 aggregates; and
3. Alluvial diamonds that may be present in the gravels under the sand deposit, or in other parts of the farms Remaining Extent of Portion 1 -, Remaining Extent – and Portion 3 of Woodlands 407.

Figure 1 & Figure 2 illustrate the resource distribution for sand and aggregate in relation to the proposed alternative sites for the processing plant. Figure 3 & Figure 4 propose a 30 year mining sequence for silica sand and aggregates respectively. Diamond mining will only commence once further testing of the gravels underneath the silica sand has been conducted.

Figure 5 - Figure 7 illustrate draft layouts for the sand beneficiation plant. Most of the sand processing will occur at this point. Gravels and diamonds will be processed at the point of extraction which will move as the resource is being excavated. Further details are provided in the following sections.

### Resource distribution and alternative processing plant locations

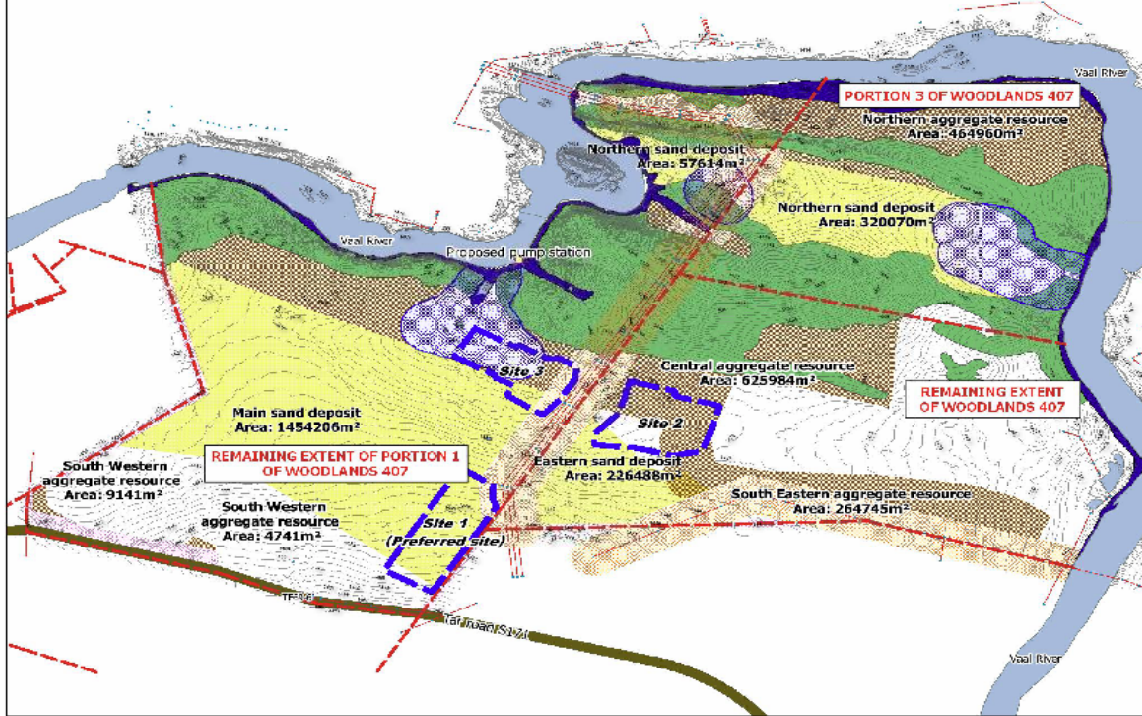

Figure 1: Resource distribution and alternative processing plant locations

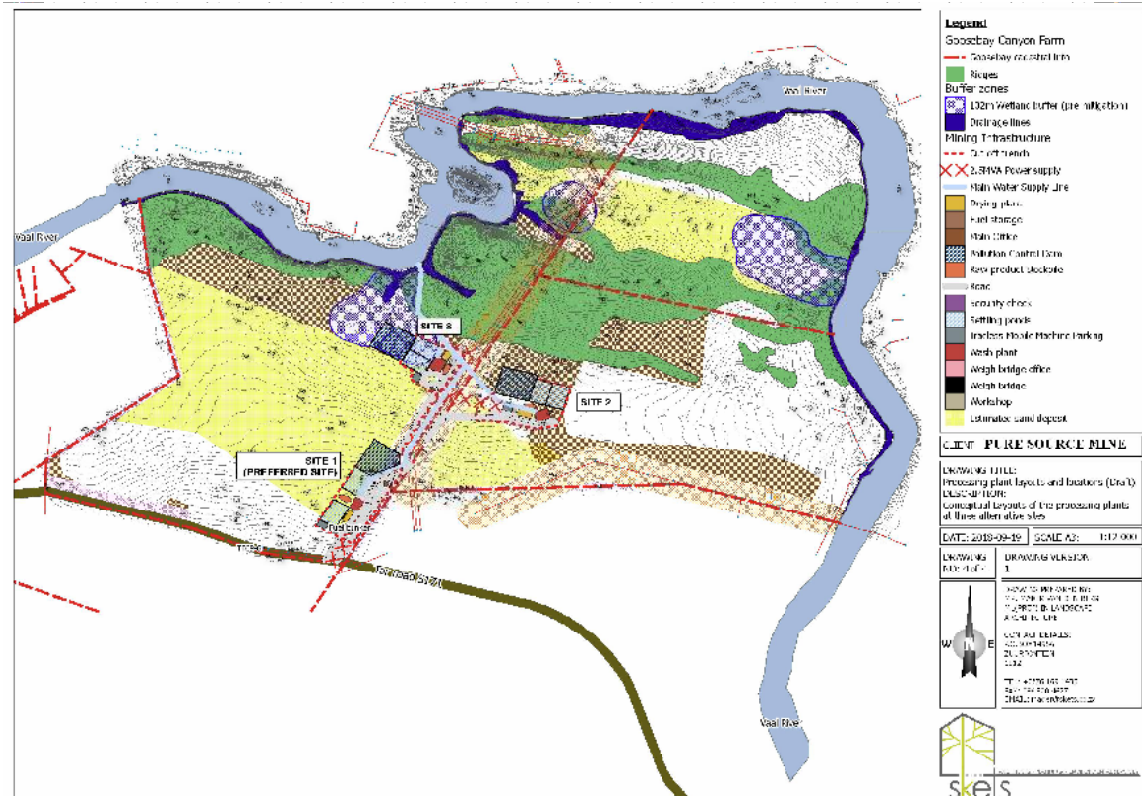

Figure 2: Proposed layouts of all alternative processing plants



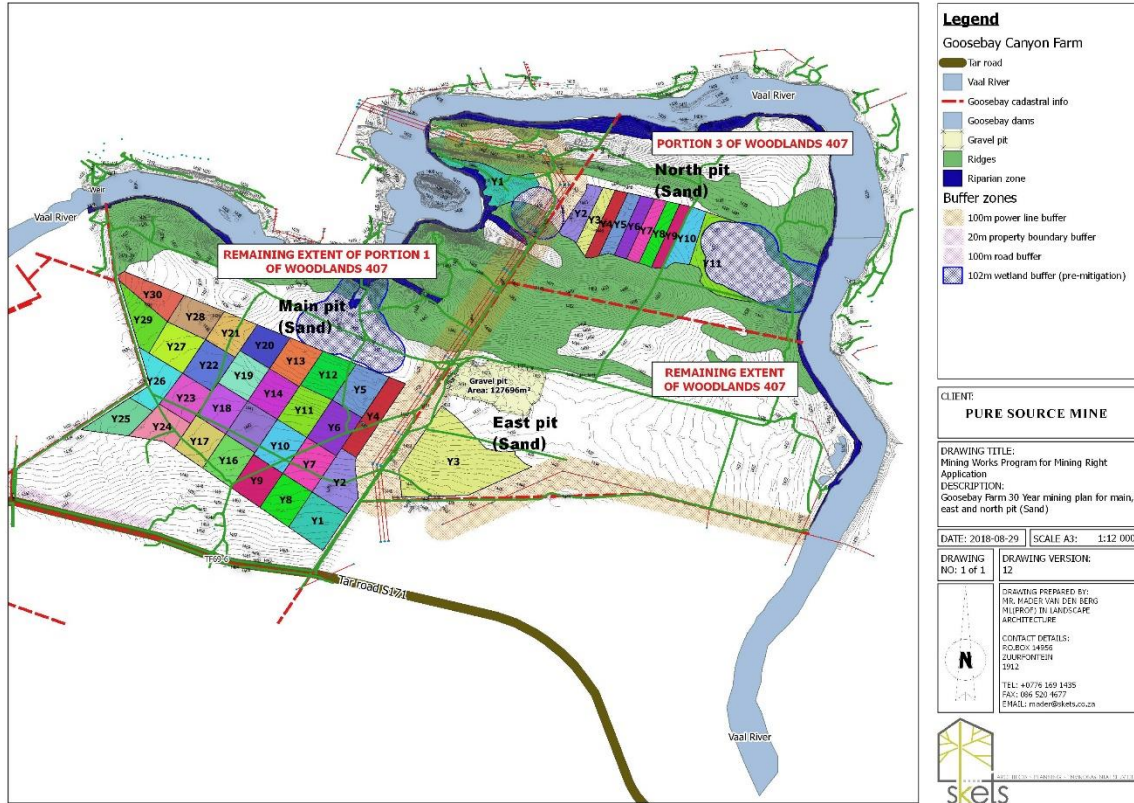

Figure 3: Silica sand - 30 year mine plan

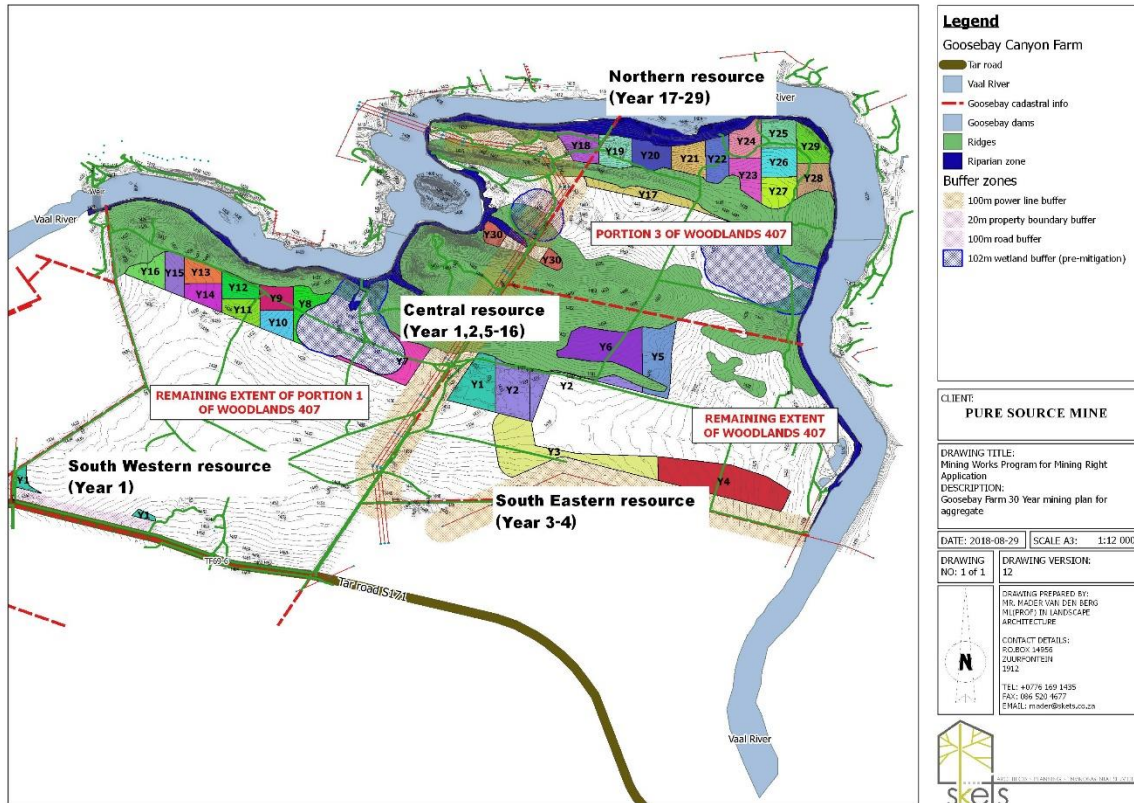

Figure 4: Aggregate - 30 year mine plan



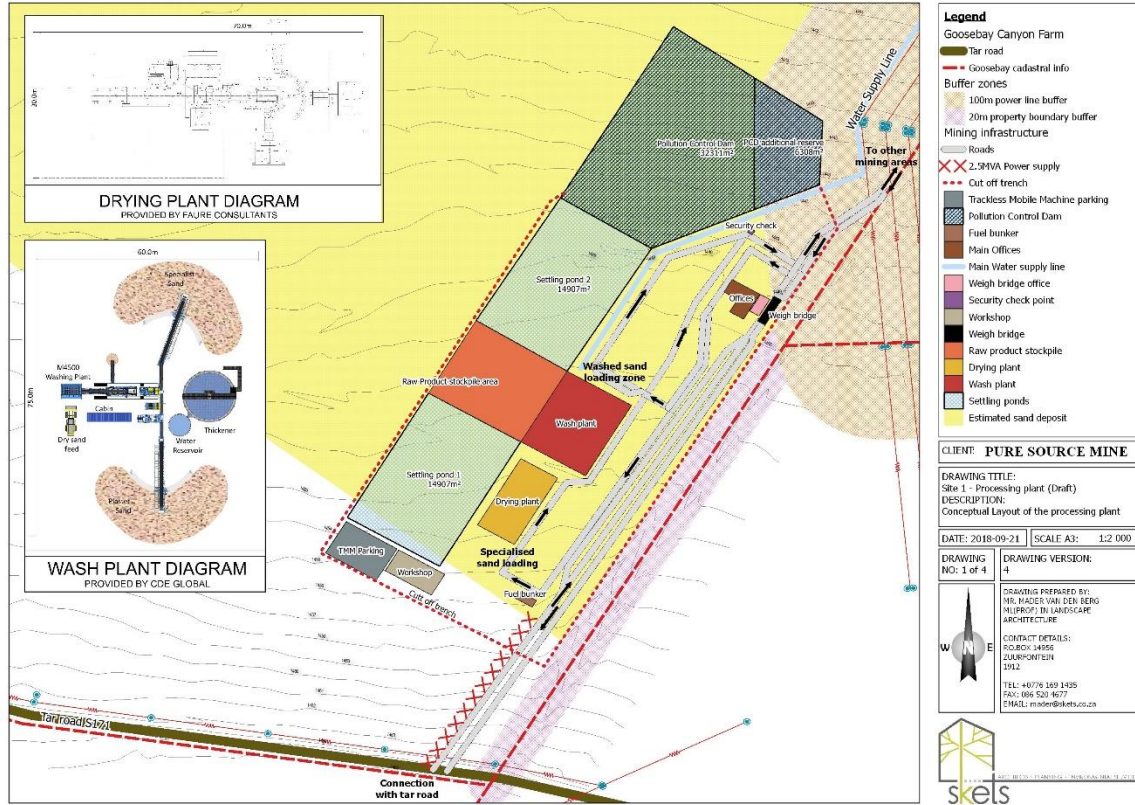

Figure 5: Site 1 draft processing plant layout

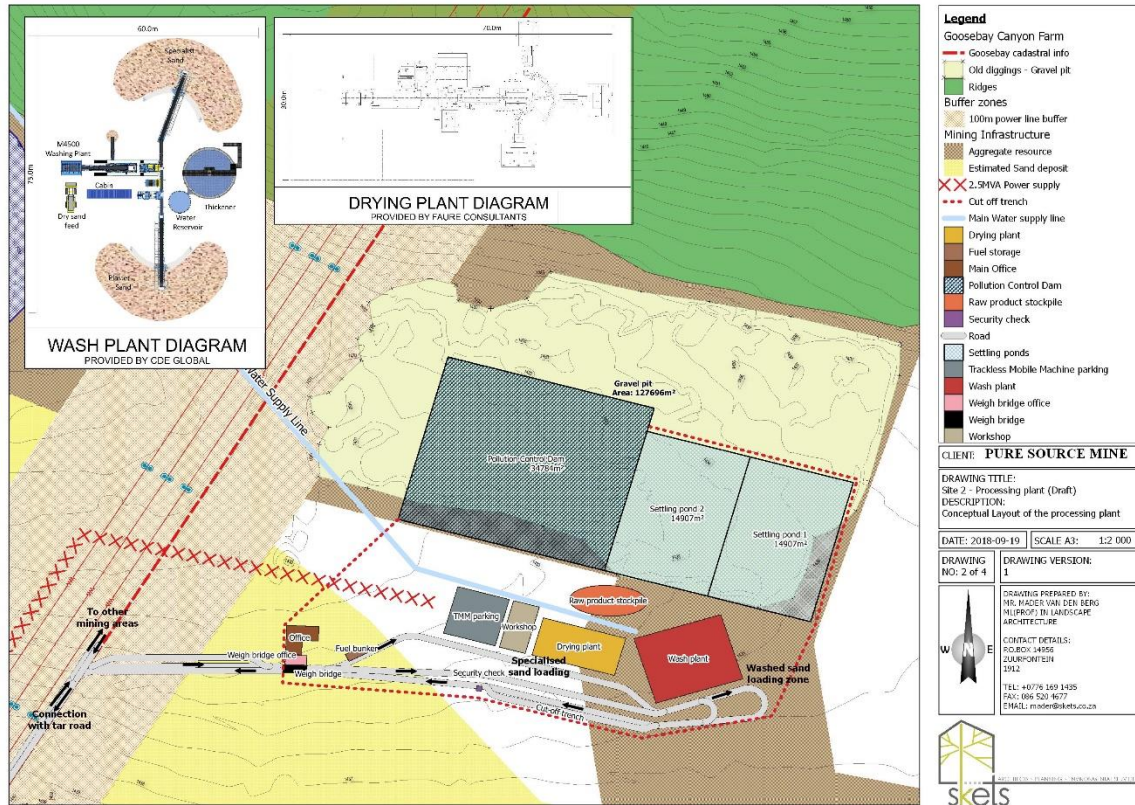

Figure 6: Site 2 draft processing plant layout



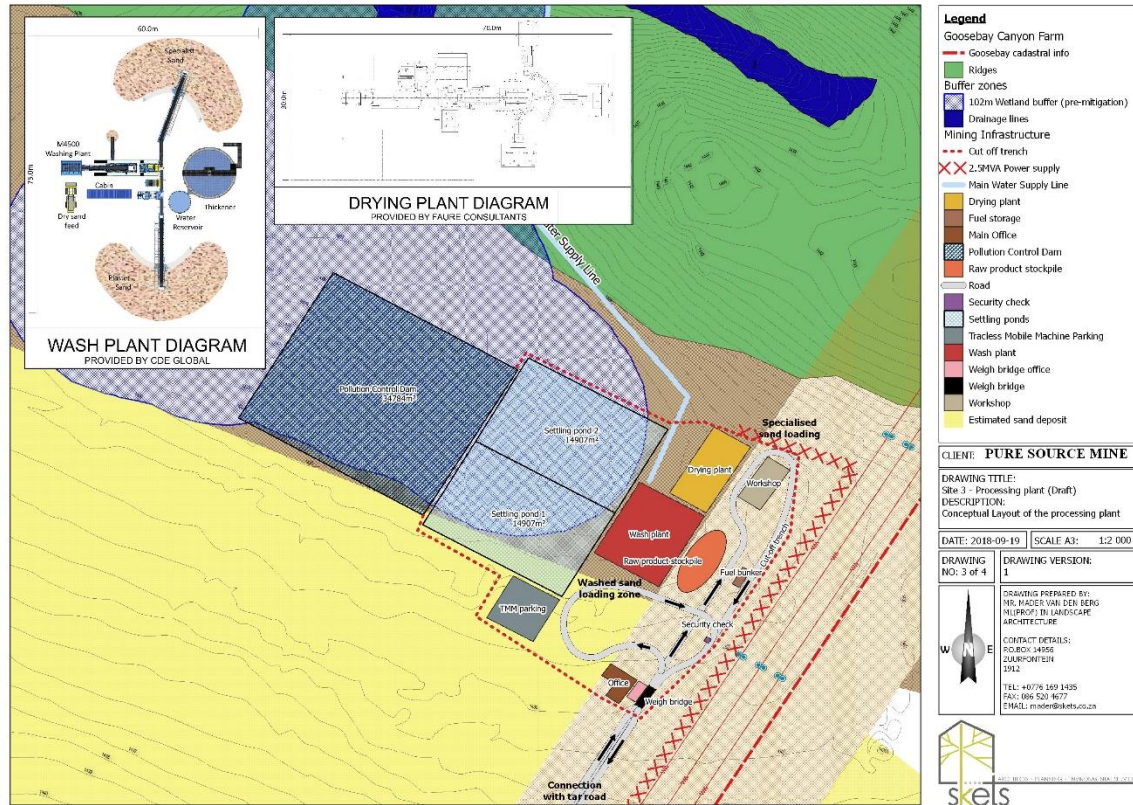

Figure 7: Site 3 draft processing plant layout

## 2 DESCRIPTION OF MINING METHODS AND EQUIPMENT TO BE USED

### 2.1 SAND PROCESSING

The sand mining activity requires beneficiation of a portion of the sand to achieve the standard for specialised sand products. All of the sand from the pits will be beneficiated by means of mobile screens (Figure 10) after which a certain percentage will be immediately sold as building and plaster sand. The remaining product will be washed, dried and kept in silos for the specialised sand market. This requires a processing plant with storage facilities (See Figure 8 for process diagram).

The sand will be transported to the processing plant via a conveyor system or by dump truck. Once at the wash plant, the sand will be tipped into a bin and then conveyed to wet screens for removal of oversized material and vegetation. The screened sand will be divided into two processes. The first portion of sand is screened for plaster sand where the fine dust particles are washed and cycloned out. The sand size fraction unsuitable for plaster sand that was screened out, will be dewatered and stockpiled (See Figure 9 for a flow diagram of the wash plant and Figure 11 - Figure 17 of examples of a wash plant).

The second half of the process will fine screen the material. The oversize material will report to the plaster sand and the screened material will pass through attrition cells where it is washed to remove any impurities. Subsequently, the material will be water cycloned, with the finer particles (Counter



Flow Classifications Unit - CFCU) being removed by gravity to then report to the plaster sand stockpile. The remaining screened material will report to the specialist sand stockpile. This stockpiled sand is then loaded into the drying plant to remove the moisture before dispatch. Two types of drying plants are being considered namely the Rotary drying plant and the Fluid Bed drying plant (Figure 18 - Figure 23)

Both the wash plant and the drying plant will be housed under a roof structure, similar to a shed. The final designs, sizes and placements are still to be confirmed based on engineering input. A summary of the plant components and their respective dimensions are tabulated in Table 2.

The other structural ancillary facilities are a workshop, fuel bunker, administrative offices, change rooms, weighbridge and security control points.

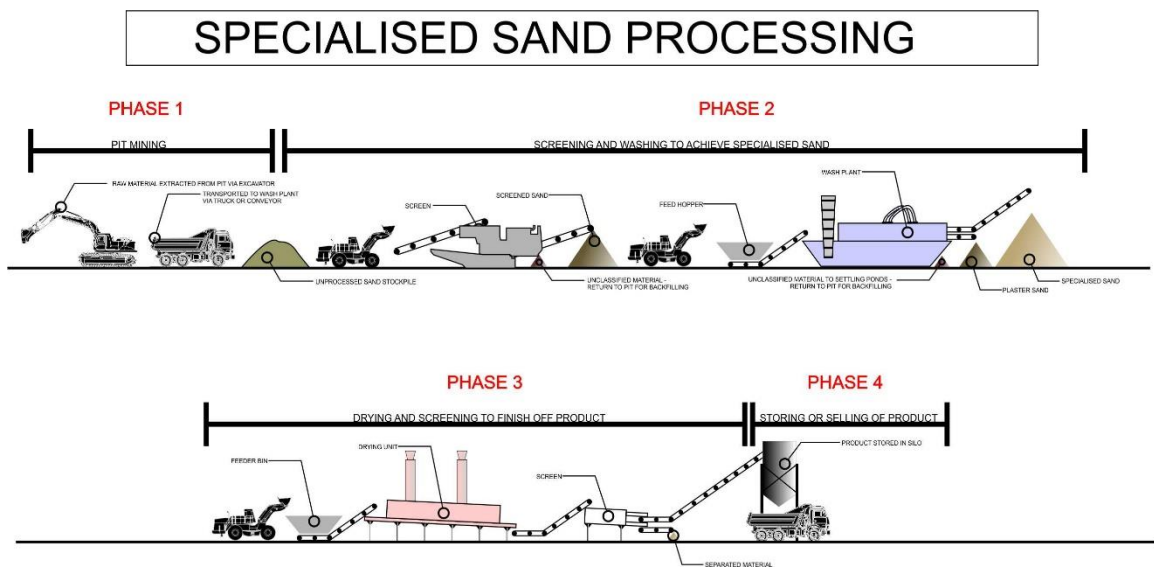

Figure 8: Specialised sand processing

# WASH PLANT PROCESS DIAGRAM

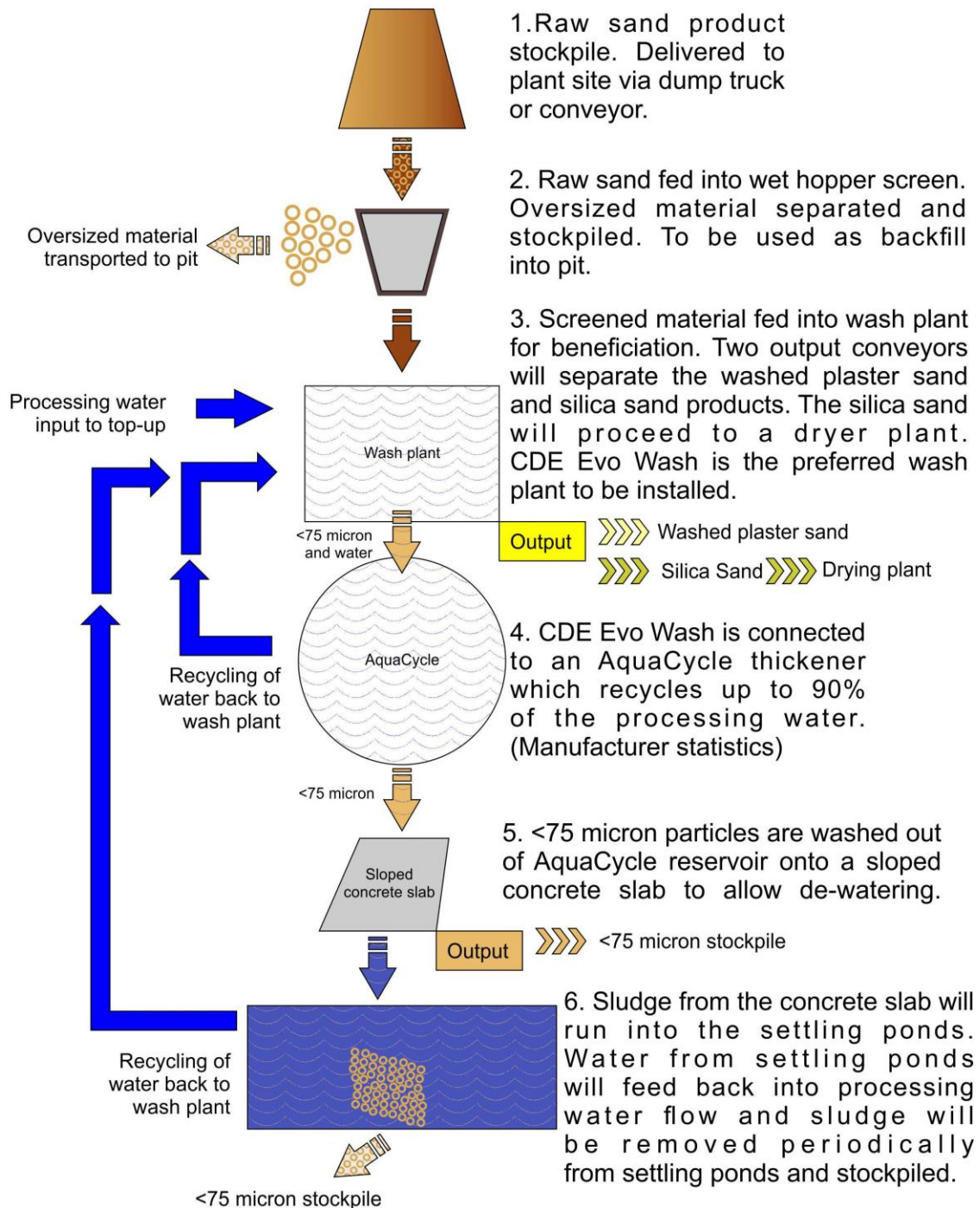

Figure 9: Flow diagram illustrating the wash plant

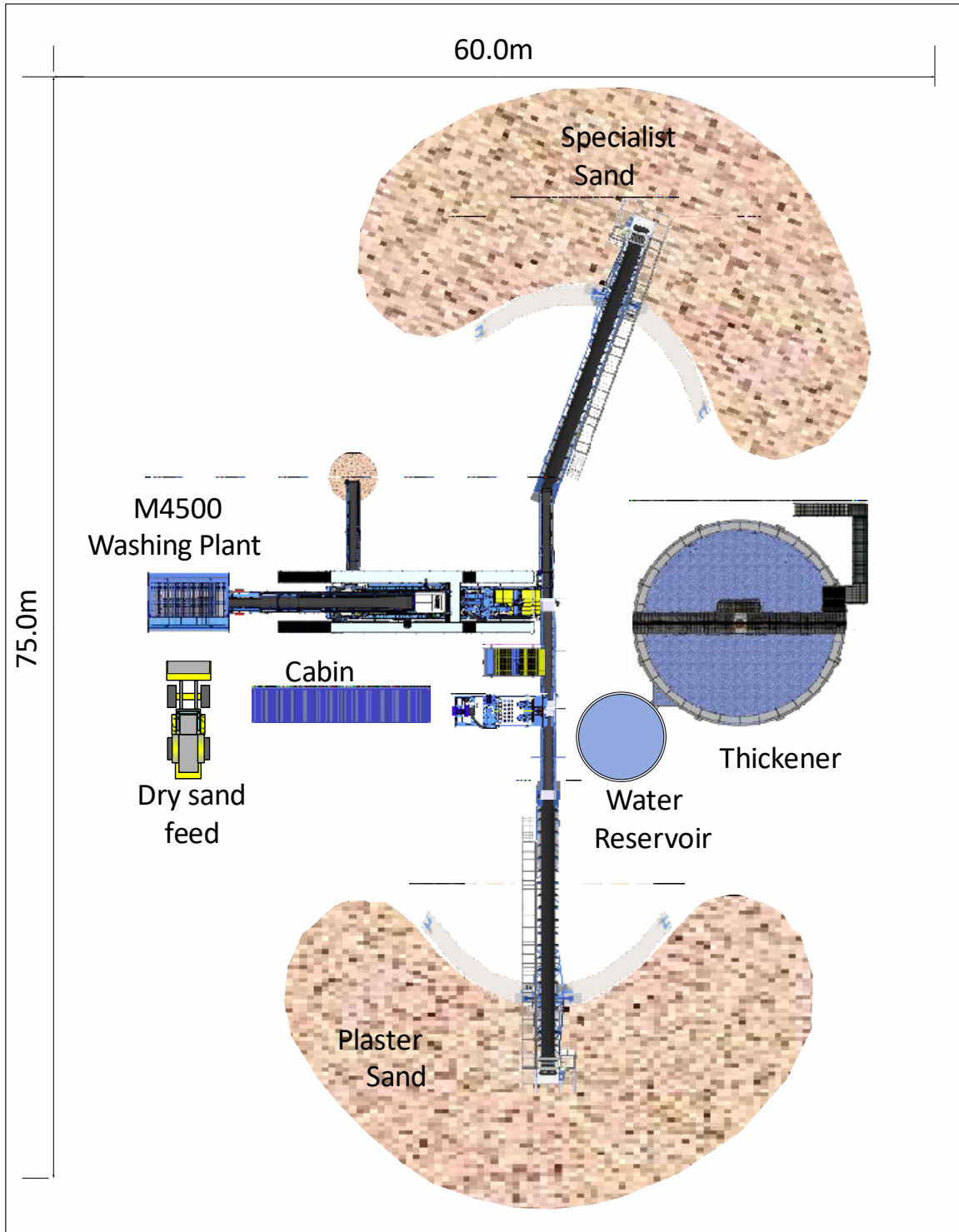

**Figure 10: Mobile screen**

**Table 1: Technical specifications of a mobile screen**

KEY SPECIFICATIONS	QA441	KEY SPECIFICATIONS	QA441
<b>Hopper</b>		<b>Side conveyors</b>	
Type	Hydraulic tipping grid	Discharge height	5090 mm / 16' 8"
Grid open area	2200 x 4010 mm / 7' 2" x 13' 2"	Width	700 mm / 27.5"
Grid area with sides open	2200 x 4735 mm / 7' 2" x 15' 6"	Drive	Hydraulic motor 395 cc
Tipping grid angle	96°	Head drum	228 mm / 9"
Vibrating grid angle	34°	Tail drum	216 mm / 8 1/2"
Standard aperture	128 mm / 5"	Length	10,551 mm / 34' 7"
Capacity	7.5 m <sup>3</sup> / 9.8 yd <sup>3</sup>	<b>Fines conveyor</b>	
Maximum capacity	11.33 m <sup>3</sup> / 14.8 yd <sup>3</sup>	Discharge height	4988 mm / 16' 4"
Length	4540 mm / 14' 11"	Width	1200 mm / 47"
Width	1926 mm / 6' 4"	Drive	Hydraulic motor 395 cc
<b>Feed conveyor belt</b>		Head drum	228 mm / 9"
Width	1200 mm / 3' 11"	Tail drum	216 mm / 8 1/2"
Length	3890 mm / 12' 9"	Length	7,976 mm / 26' 2"
Motor	125 cc	<b>Tracks</b>	
Gearbox ratio	R 26:1	Length	3800mm / 12' 5"
Head drum	325 mm / 12 1/2"	Width	500mm / 20"
Tail drum	270 mm / 10 1/2"	<b>Power pack</b>	
Belt speed	18 m/min	Engine type	CAT C4.4 74.5 kW / 100 hp
<b>Main conveyor</b>		Diesel tank size	290 Litres / 76.5 USG
Width	1000 mm / 3' 3"	Hydraulic tank size	370 Litres / 98 USG
Length	12,390 mm / 488"	<b>Transport dimensions</b>	
Drive drum	282 mm / 11"	Length	18,680 mm / 61' 3"
Tail drum	270 mm / 10 1/2"	Width	2,900 mm / 9' 6"
Motor	490 cc	Height	3,500 mm / 11' 6"
Belt speed	127 m/min	<b>Operating dimensions</b>	
<b>Screenbox</b>		Length	18,890 mm / 62'
Type	2 bearing	Width	18,720 mm / 61' 5"
Decks	2 deck	Height	6,743 mm / 22' 1"
First screen box size	3048 x 1524 mm / 10' x 5'	Standard weight	30,300 kg / 66,800 lbs
Second screen box size	3048 x 1524 mm / 10' x 5'	<b>Performance</b>	
Tensioning system	Ratchet	Max feed size	200 mm / 8"
Speed	1200 rpm	Capacity (up to)	600 MTPH / 661 STPH
Throw	7.24 mm		
Motor	49.1 cc x 2 off		

Note. All weights and dimensions are for standard units only



# WASH PLANT DIAGRAM

PROVIDED BY CDE GLOBAL

Figure 11: Example of an M4500 Dual Sand EvoWash plant layout



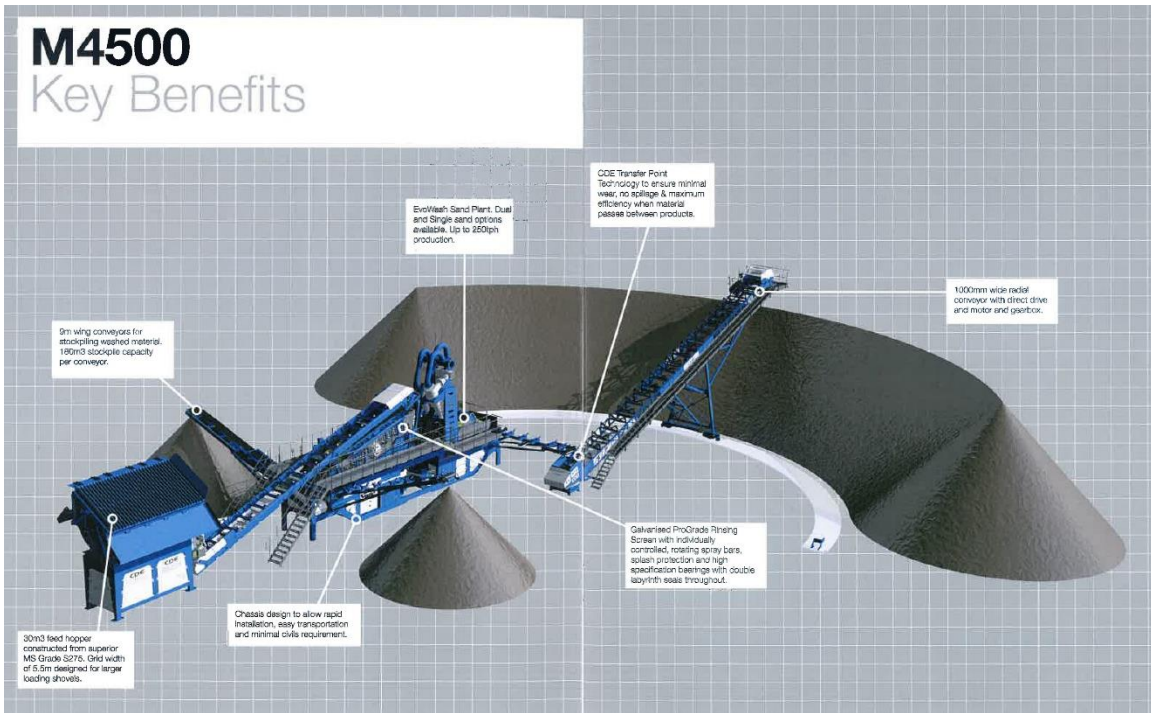

Figure 12: Operations diagram of a M4500 EvoWash plant



Figure 13: Example of an EvoWash plant





Figure 14: Example of an EvoWash plant with AquaCycle (1)



Figure 15: Example of an EvoWash plant with AquaCycle (2)

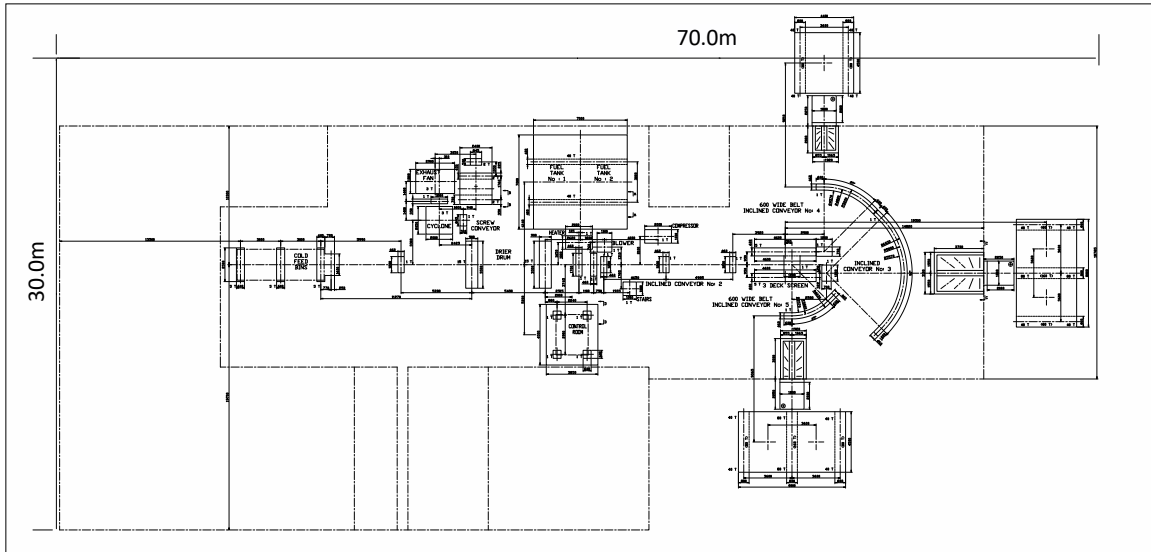



Figure 16: Example of an EvoWash plant with AquaCycle (3)

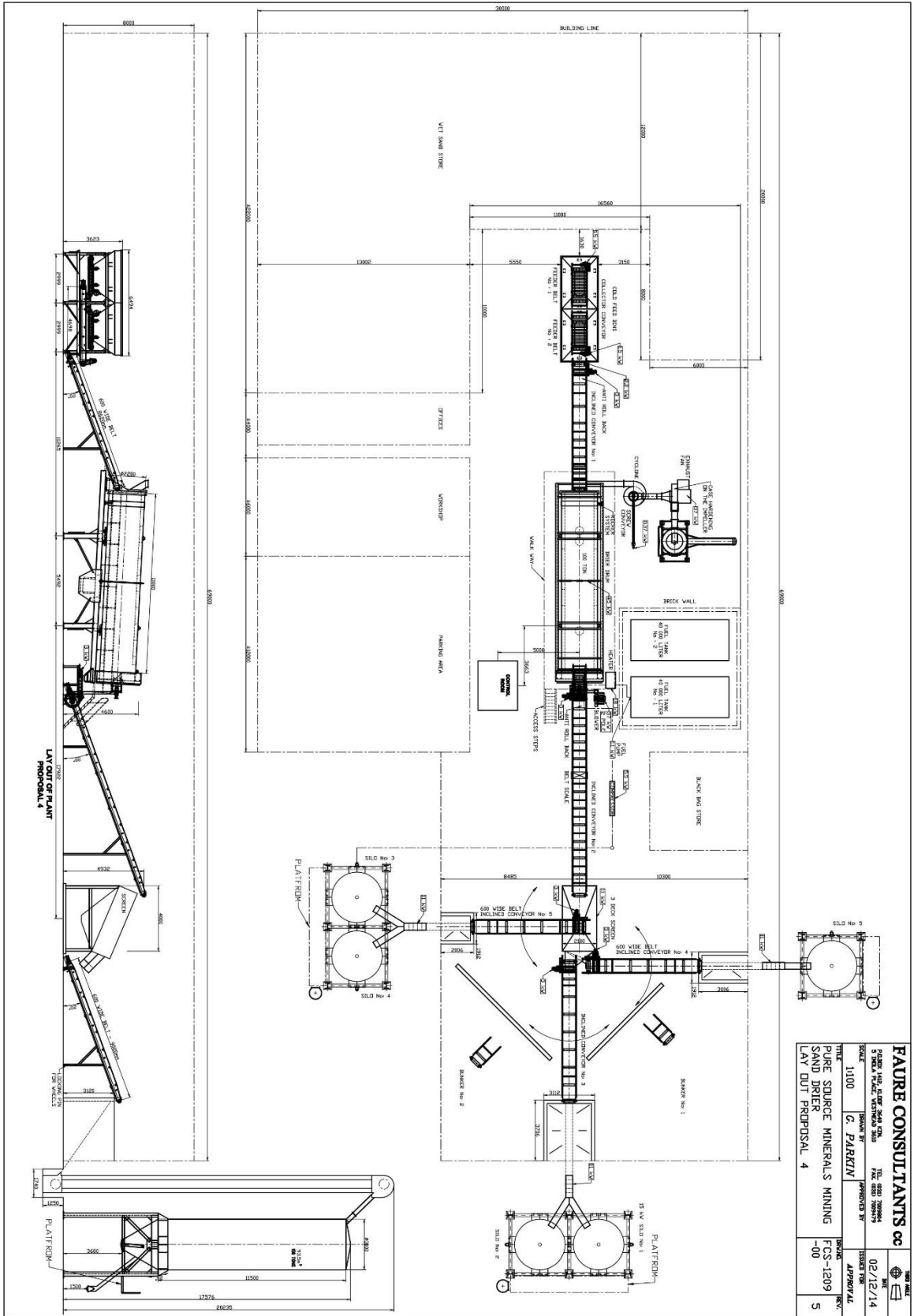

Figure 17: Example of a EvoWash plant with AquaCycle(4)



**DRYING PLANT DIAGRAM**  
 PROVIDED BY FAURE CONSULTANTS

Figure 18: Example of a rotary drying plant



<b>FAURE CONSULTANTS cc</b>		<b>REG. NO. 12345</b>	
PURE SOURCE MINERALS MINING		TEL: 021 234 5678	
SAND DRIER		FCS-1209	
LAY OUT PROPOSAL 4		ISSUE APPROVAL	
SCALE: 1:100	DATE: 02/12/14	DESIGNER: C. ZABRYN	REVISION: 5

Figure 19: Typical layout of a rotary drying plant



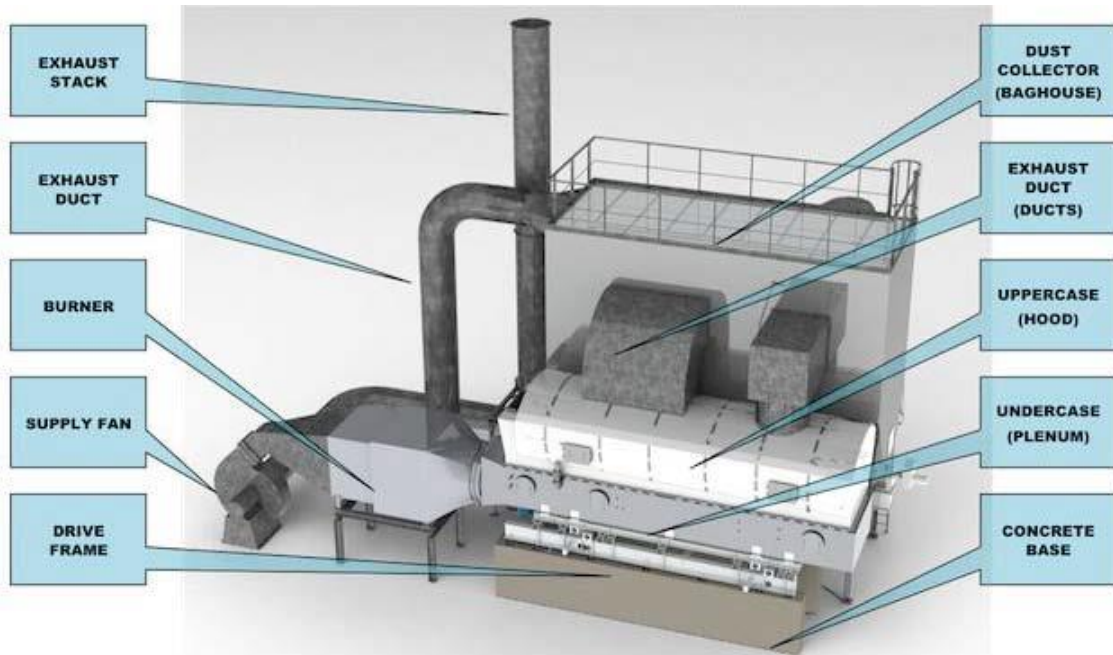

Figure 20: Schematic of a typical fluid bed sand drying unit

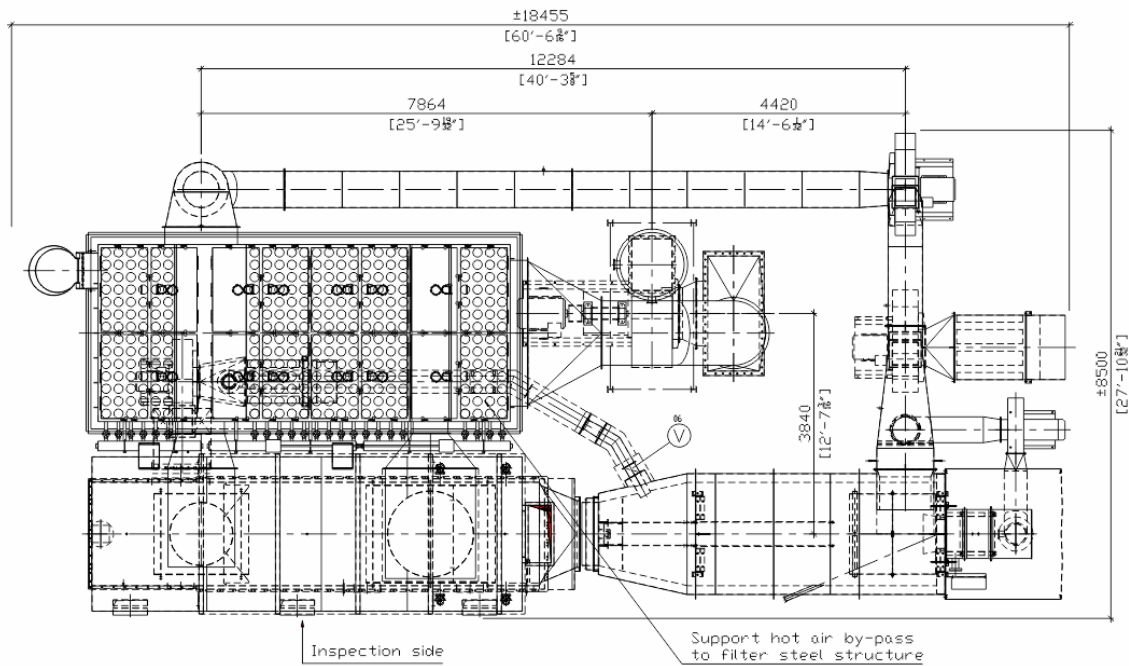

Figure 21: Plan view of a typical fluid bed sand drying unit

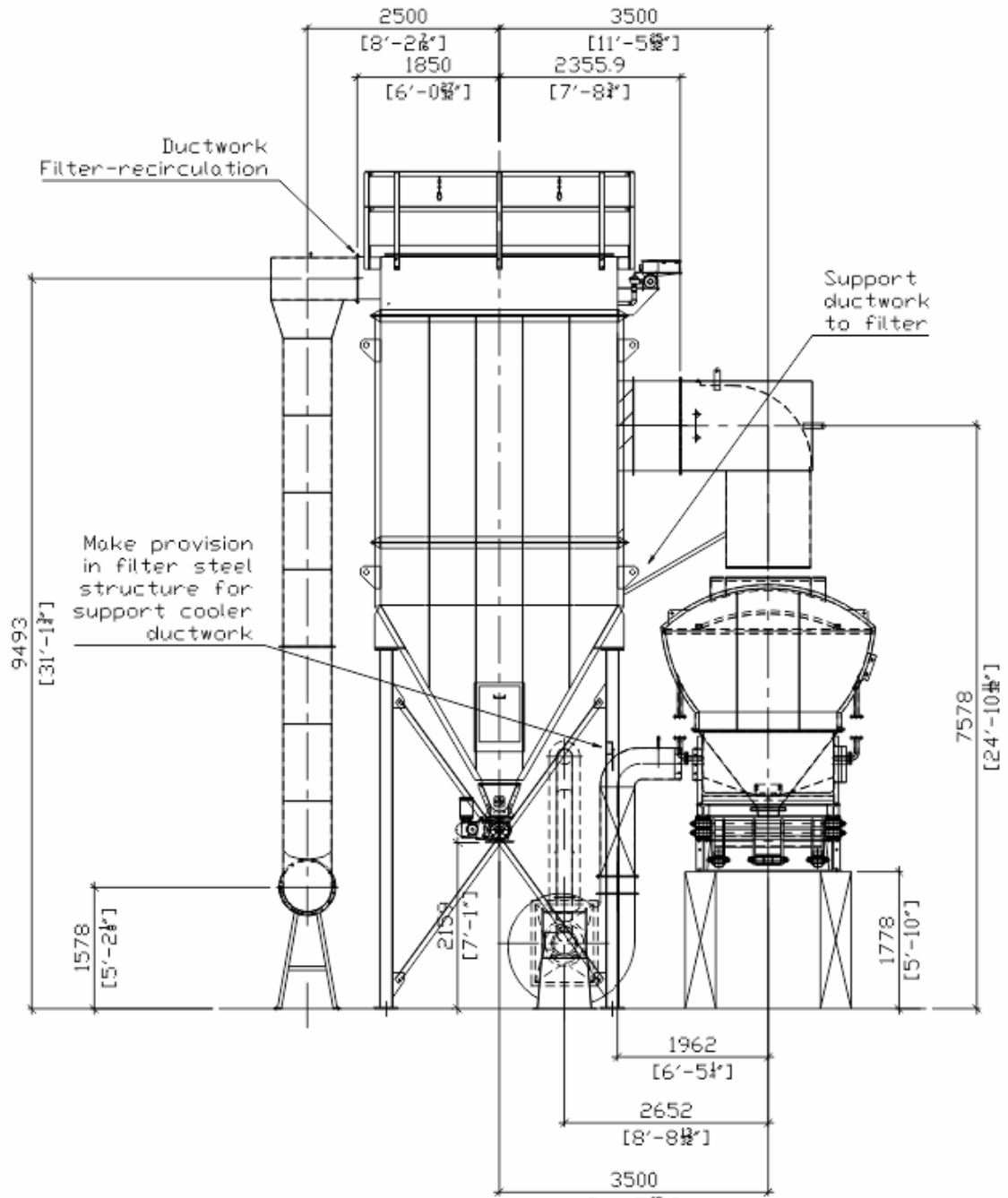

Figure 22: Typical elevation (1) of a fluid bed drying unit

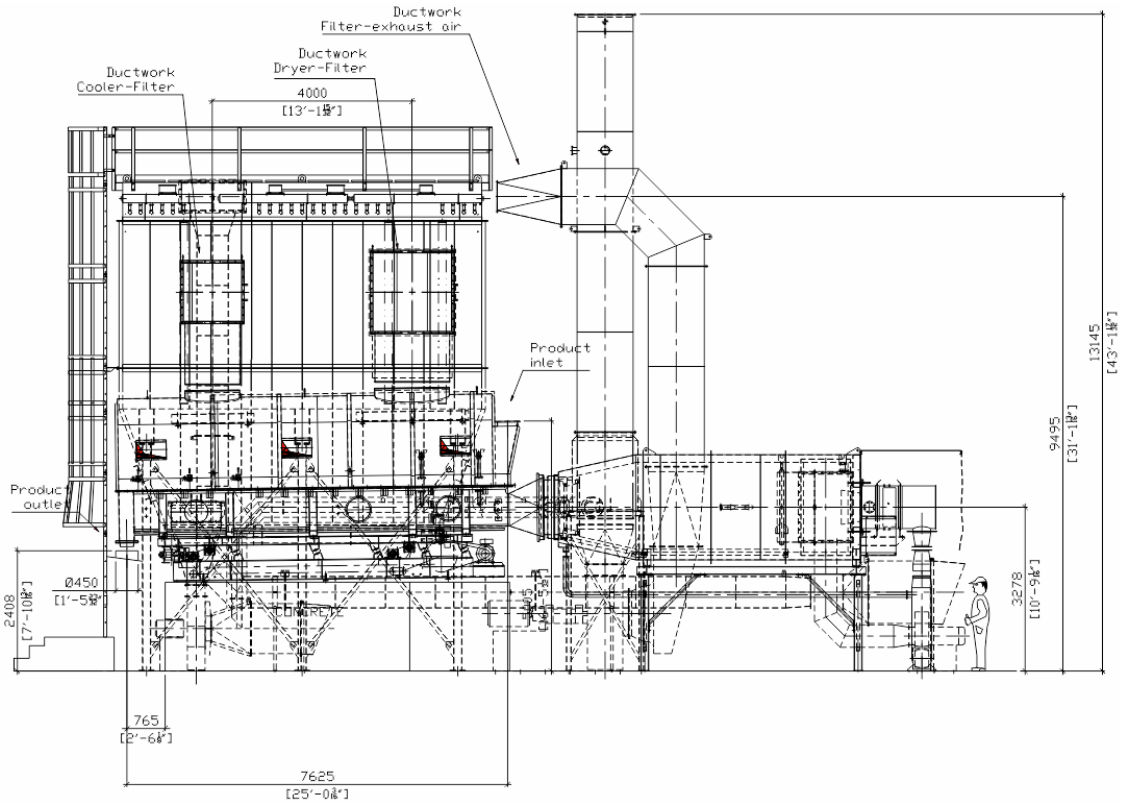

Figure 23: Typical elevation (2) of a fluid bed drying unit

Table 2: Sand processing plant – Dimensional data

	Length	Width	Height	Allowed Footprint
Mobile Screen	18,89m	18.72m	6.7m	N/A
EvoWash M4500 dual sand (capacity 150T/H)	6.8m	2.3m	8m	85x70m 5 950m <sup>2</sup>
Aqua Cycle A1500	16.7m	16.7m	±6m incl. catwalk	
Rotary drying plant	49m (from feeder bins to silo)	18.7m	6m (excl. silos) 250t silo = 25,5m 200t silo = 21.4m 150t silo = 17.2m	80x40m 3 200m <sup>2</sup>
Fluid bed drying plant	18.5m	8.5m	13.14m (excl. silos) 250t silo = 25,5m 200t silo = 21.4m 150t silo = 17.2m	80x40m 3 200m <sup>2</sup>
Workshop area	100m	30m	±10m	100x30m 3 000m <sup>2</sup>
Fuel bunker area	20	8	±4m	160m <sup>2</sup>
Administrative offices And weighbridge office	Not yet determined	Not yet determined	Triple storey	60x40m 2 400m <sup>2</sup>
Run of Mine stockpile (±48 000m <sup>3</sup> capacity)	100m	80m	±6m	100x80m 8 000m <sup>2</sup>



<p><b>NOTES:</b></p> <p>The illustration is for presentation purposes only and although every effort has been made to keep the scale as accurate as possible, an unknown percentage of discrepancy may be expected.</p> <p>This illustration is a block model of the proposed processing plant to beneficiate sand. The total footprint is approximately 14 Ha which mostly consists of processing water treatment facilities and circulation routes.</p> <p>Infrastructure such as the wash- and drying plant is expected to be contained within shed structures. The dimensions and placements of these sheds are unknown at this point in time and further specifications are still to be developed.</p>	<p><b>CLIENT:</b></p> <p>PURE SOURCE MINE</p>
	<p><b>DRAWING TITLE:</b></p> <p>Proposed plant layout for the sand beneficiation for Monte Cristo Commercial Park (Pty) Ltd.</p> <p><b>DESCRIPTION:</b></p> <p>Three-Dimensional layout of proposed processing plant for sand beneficiation on Remaining Extent of Portion 1 of Woodlands 407</p>
<p>2019-05-29</p> <p><b>DRAWING NO.:</b> 1 of 1</p>	<p><b>SCALE:</b> NOT TO SCALE</p> <p><b>DRAWING VERSION:</b> 2</p>
<p><b>DRAWING PREPARED BY:</b></p> <p>MR. MADER VAN DEN BERG ML(PROF) IN LANDSCAPE ARCHITECTURE</p> <p><b>CONTACT DETAILS:</b></p> <p>URS ZURFONTEIN 1912</p> <p>TEL: +076 169 1435 FAX: 086 520 4677 EMAIL: mader@skels.co.za</p>	<p><b>skels</b></p> <p>ARCHITECTS - PLANNING - ENVIRONMENTAL SERVICES</p>

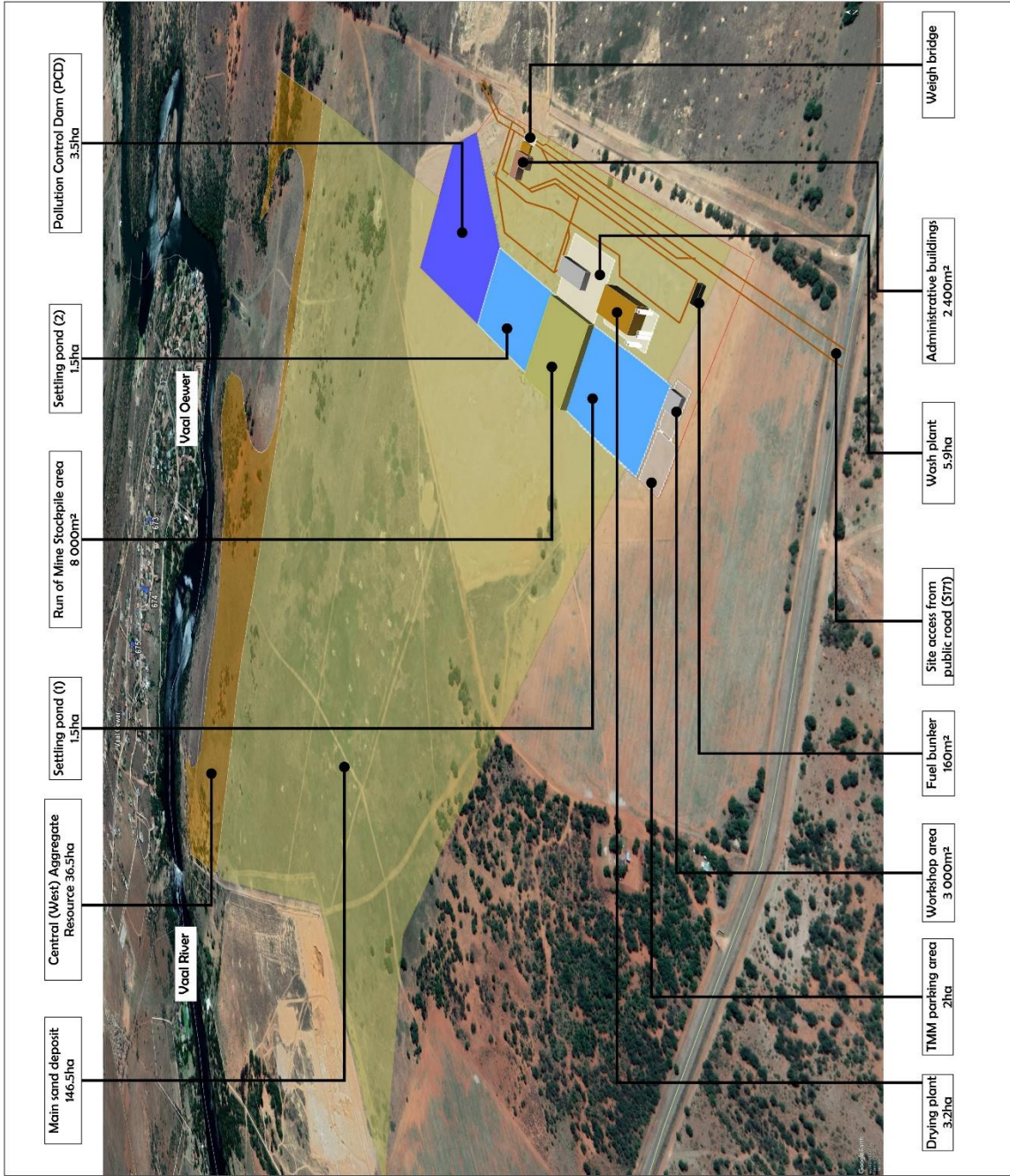

Figure 24: Block diagram illustrating sand processing plant



## 2.2 AGGREGATE PROCESSING

Mobile crushing plants will be used in the pit to size aggregates before loading onto customer's trucks. A processing diagram in Figure 25 illustrates the flow of the process. These will be tracked diesel machines as depicted in Figure 26.

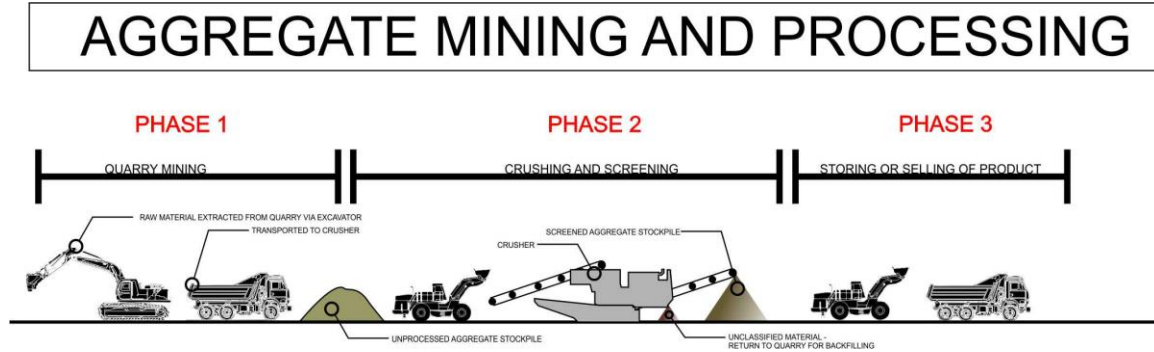

Figure 25: Aggregate mining and processing



Figure 26: Example of mobile crusher

# TRANSPORT & WORKING

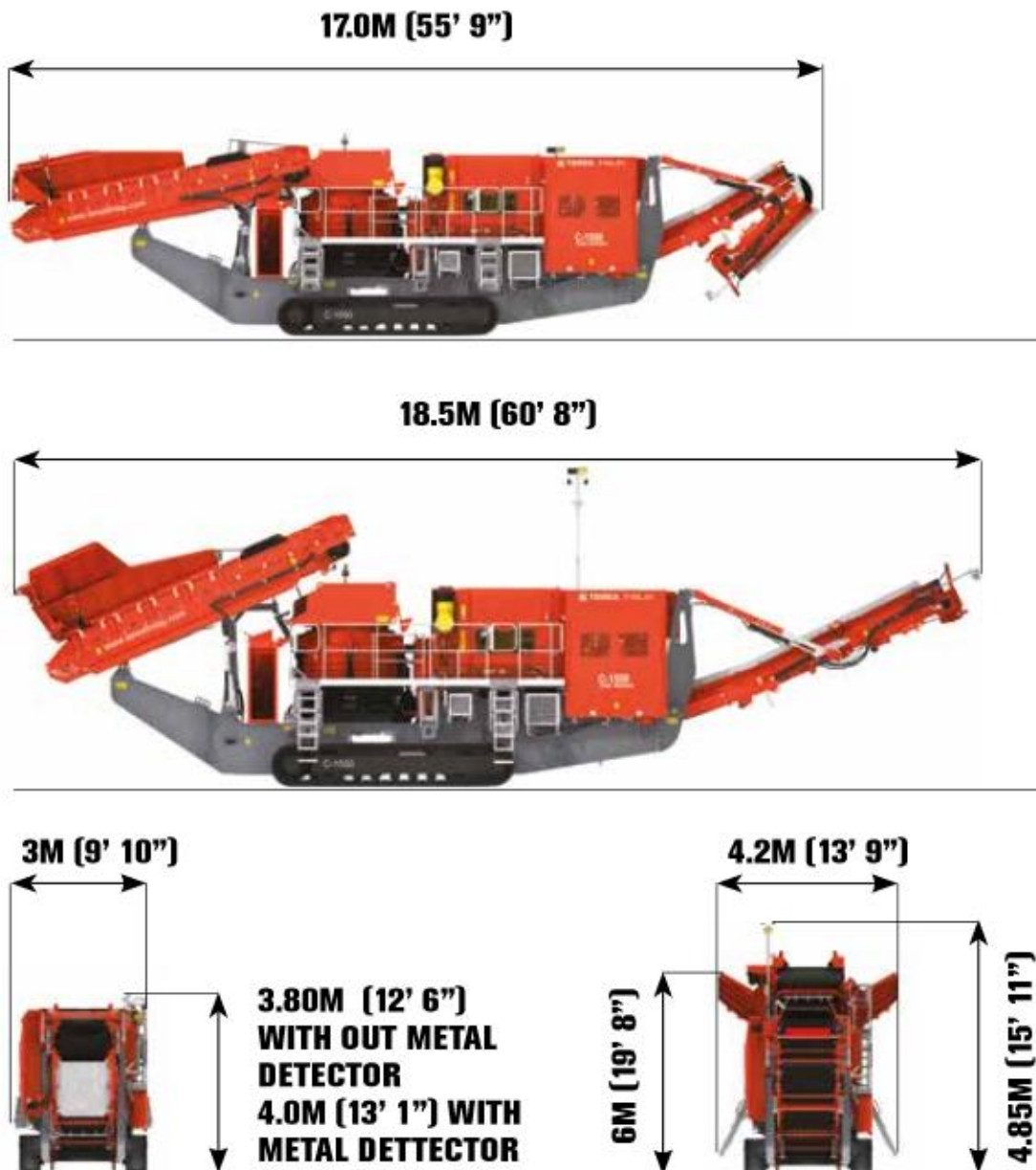

Figure 27: Terex Finlay C-1554 dimensions

## 2.3 DIAMOND PROCESSING

Should diamond potential be established via exploration, the proposed extraction strategy is outlined in the following steps and illustrated in Figure 29:

The overburden is removed – the topsoil will be stockpiled as per the current programme for the sand mining and the sand is excavated and diverted to the current sand mining operation.

The basal gravel unit is screened – the oversize is sent back to any open excavation as rehabilitation infill, the -2 mm is forwarded to the sand mining operation and the +2-32 mm fraction are stockpiled as plant feed. Generally, a permanent screening plant is constructed in a central location or a mobile screen is used similar to Figure 26. As a sampling plant, a rotary pan plant is recommended. This plant is mobile, easy to operate and very accurate for sampling. The process contains no deleterious or toxic chemicals and has limited requirements on both, power and water quality/quantity. All of the plant's waste can be trucked directly back to open excavations as part of the backfill. Some of the fines can be used as a surface dressing, prior to the return of the stockpiled topsoil and the rest can be stored in a small fines residue dam, from which water can be recovered for circulation back to the plant.



Figure 28: Typical rotary pan plant for sampling

Should it be proven that the extraction of diamonds is economically viable, a larger more permanent plant may be erected. The following components may form part of it:

- At the plant site the screened gravel is fed into a scrubber plant to wash the gravels from clay particles.
- The concentrate from the scrubber will then be conveyed to a final recovery circuit comprising of a single-stage FlowSort X-ray recovery unit (Figure 32 - Figure 35), followed by hand-sorting in a secure facility.



The location of the rotary pan or processing plant will be at the diamond recovery site. The x-ray sorter's location has not been determined yet and will be a function of where the biggest potential for diamonds are.

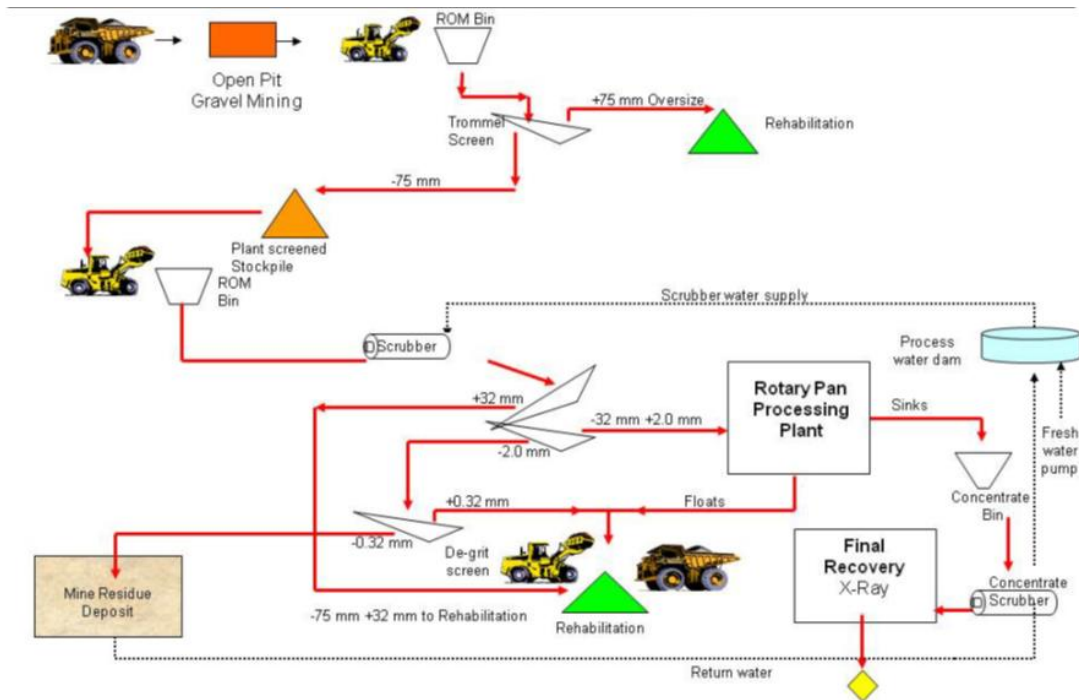

Figure 29: Diamond extraction flow diagram



Figure 30: Typical excavation process





**Figure 31: Typical simple exploration plant**

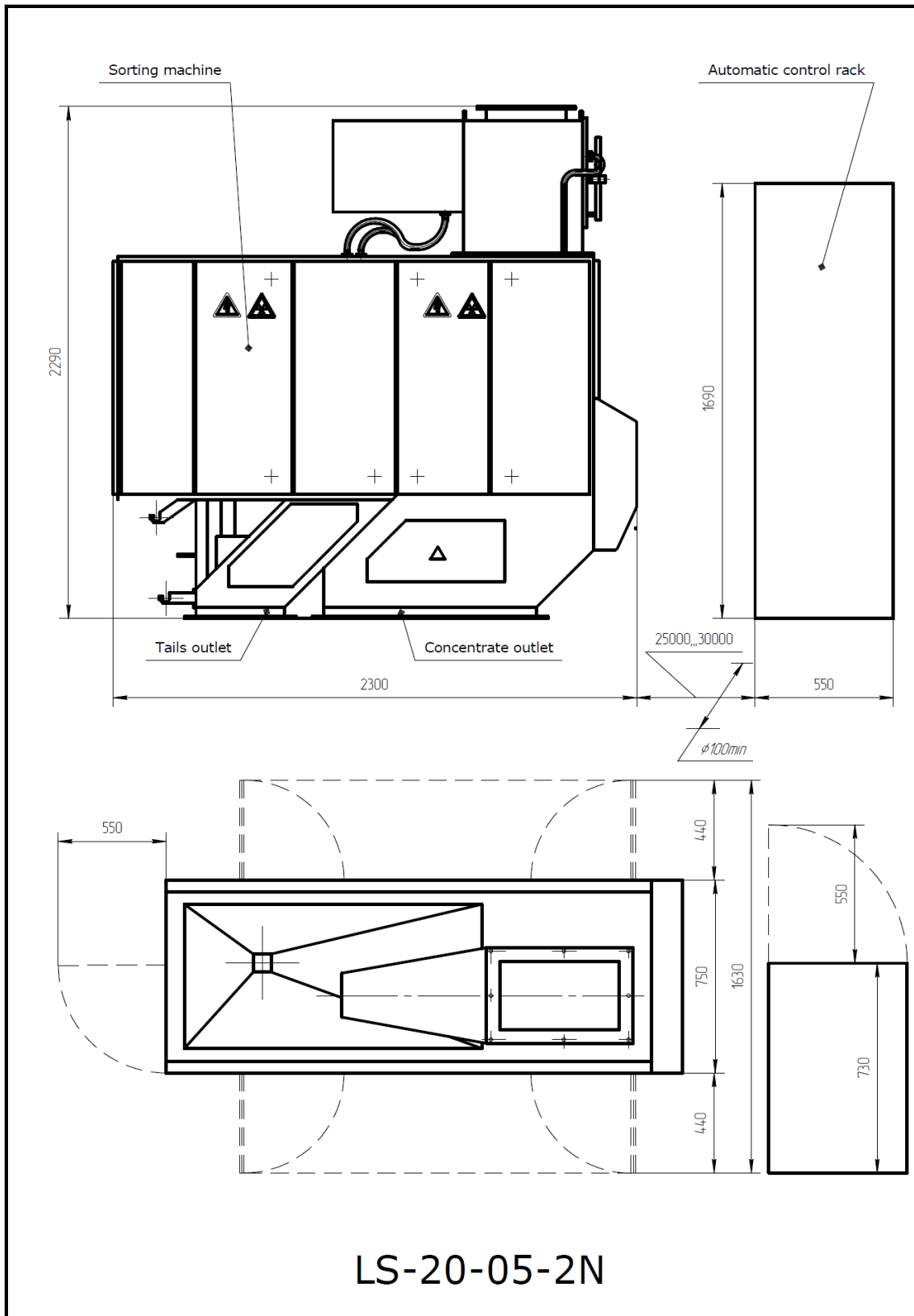

Figure 32: X-ray luminescence sorter LS-20-05-2N

**Table 3: Technical specifications for X-ray luminescence sorter LS-20-05-2N**

<b>Technical data</b>	
Material to be processed	Wet, clean from clay and slurries, classified (contents of the main class - 85% minimum)
Material grain size fraction	- 50 + 20, - 20 + 10 mm.
Material supply and transportation system	Continuous flow system, single-stage with gravity feeder. Non-single layer supply of material to the analysis area is allowed.
Throughput	100 t/h (- 50 + 20 mm) 60 t/h (- 20 + 10 mm)
<b>X-ray:</b>	
number of X-ray tubes	2 Two-sided exposure on material flow in the freefall tray.
mode of radiation	Pulse type (pulse duration - 0.5 ms; pulse period - 4 ms)
anode voltage, anode current	(33-2) kV max.; (330±10) mA
<b>Detection:</b>	
Two-sided material luminescence detection. Analogue-to-Digital Processing System; operation both in amplitude-time mode and in special mode (increased selectivity, using kinetic features of luminescence) is possible.	
luminescent signals' receivers	Photomultiplier tubes (PMT)
number of detectors, detection channels	4 (2 on each side of the material flow).
Ejection	Pneumatic, with compressed air, by means of solenoid-operated pneumatic valves. 4-channel stopping mechanism. Ejection by all 4 valves simultaneously, irrespective of the channel where luminescence was detected.
Recovery rate	98% minimum
Yield per ejection (with rated capacity)	Max. 2.0 kg (- 50 + 20 mm) 1.5 kg (- 20 + 10 mm)
Automation	Checking of main systems prior to start of material supply and in the course of operation (material supply is stopped if fault is detected). Sensitivity control. Failure indication. Monitoring and control from the APCS of enrichment plant. Protection system against unauthorized access to SM, material only if special smart cards are available.



Electric power supply	1 phase; (220±22) V; (50±1) Hz
Power consumption	5 kVA max.
Transportation water flowrate (0.2 MPa)	30 l/min min.
Flowrate of potable water to cool the tubes	6 l/min min.
Flowrate of potable water to wash the windows of photo receptors and tube collimators (0.3 MPa)	0.5 l/min max.
Volumetric compressed air flowrate (0.6 MPa)	0.6 m <sup>3</sup> /min
<b>Overall dimensions (L×W×H), mass:</b>	
SM	2300×845×2300 mm; 1400 kg
ACR	765×555×1750 mm; 230 kg

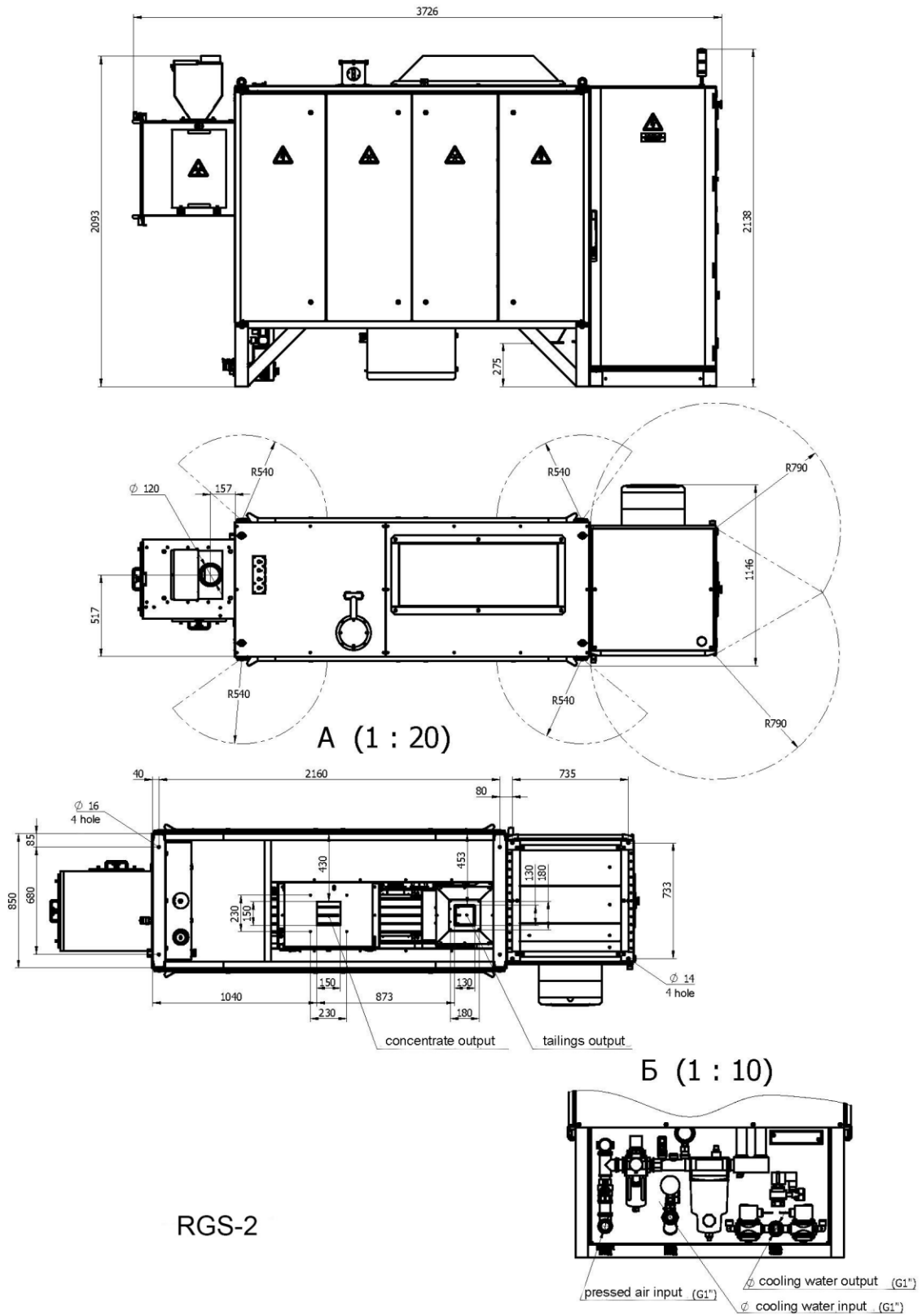

Figure 33: X-ray transmission sorter RGS - 2

**Table 4: Technical specifications for X-ray transmission sorter RGS - 2**

<b>Technical data</b>	
Material to be processed	Dry, dust-free, classified (contents of main class 85% minimum)
Material grain size fraction	-6 +3 mm
Material supply and transportation system	Flow type, 4-stream, 1-stage with supply vibrofeeder. Optional installation of collectors (tanks) for concentrate and tailings.
Throughput	1.2 t/h minimum (- 6 + 3 mm)
<b>X-ray:</b>	
number of X-ray tubes	Two (2) X-ray tubes, Mo and W, operating on low and high energy, respectively.
mode of radiation	Constant
anode voltage, anode current	37 kV, 60 mA (Mo); 60 kV, 42 mA (W)
Detection:	Detection module is provided with two rows of X-ray sensitive rulers with cell pitch of 0.4 mm (for channels of low and high energies)
Ejection	Local, pneumatic (with compressed air) 16-channel stopping mechanism (4 valves per each stream)
Recovery rate	98.5 % minimum
Yield per ejection (with maximum capacity)	0.6 g
Automation	Checking of main systems prior to start of material supply and in the course of operation (material supply is stopped if fault is detected). Failure indication.
Electric power supply	1 phase; (220±22) V; (50±1) Hz
Power consumption	8 kVA max.
Flowrate of potable water to cool the tubes	4 l/min minimum
Average compressed air flowrate (0.4 MPa)	4 m <sup>3</sup> /min
<b>Overall dimensions (L×W×H), mass:</b>	
Sorting section (SS)	2900×970×094 mm; 1185 kg
Electronic section (ES)	1125×840×2150 mm; 290 kg

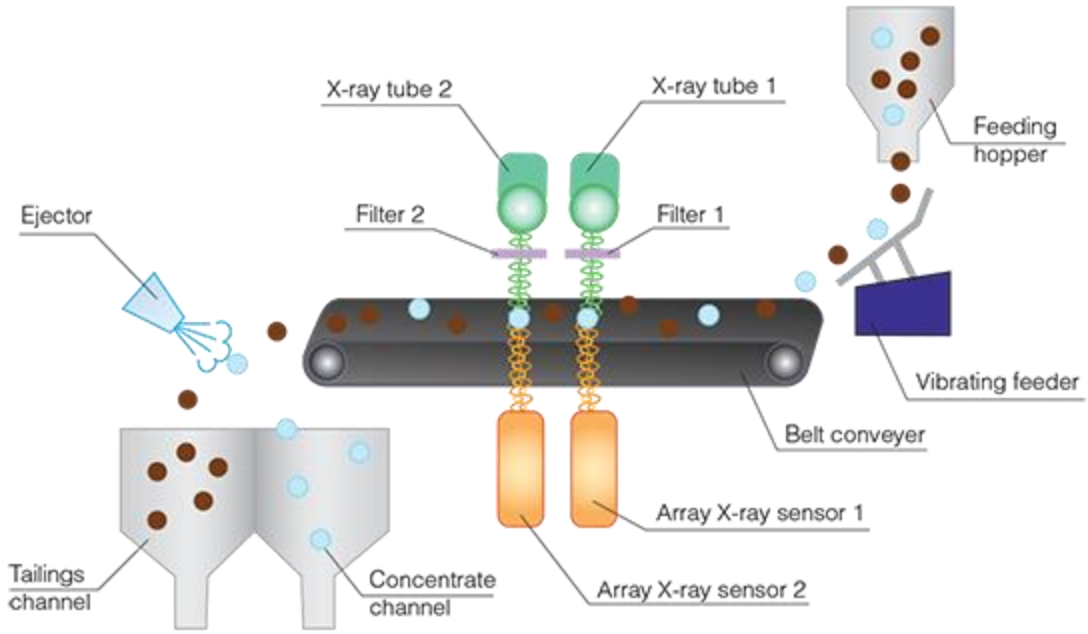

Figure 34: Process diagram of the x-ray sorter



Figure 35: Typical setup of a diamond x-ray sorter



Sincerely;

A handwritten signature in black ink, appearing to read 'M. van den Berg', written in a cursive style.

Mr. Mader van den Berg on behalf of Skets Architects and Planning